

# MRAD Universal Measuring Arm System For Optical/Magnetic and Fiber Optic Encoders

Model 8400.00.020



- Spring-loaded, adjustable measuring arm for universal applications
- Measuring wheels are utilized in combination with encoders to measure material and monitor processes in the wood, paper, metal, textile and plastic industries
- When selecting a measuring wheel, the first consideration is the type of material to be measured as this serves as the basis for determining the surface finish or coating of the measuring wheel
- Standard wheels available with 0.5-meter measuring distance (circumference) and Ø10mm bore
- Forces can be adjusted easily. Contact pressure can be adjusted in ~10-20N steps
- Measuring arm is aluminium body with stainless steel springs
- Special high temperature wheel available for hot melt applications

### Base plate

- Variable in 4 directions

### Can be installed in any mounting position

- 9 setting positions in 40° steps



### Pressure

- Max. 40 N, adjustable
- Spring pressure available in any position

## Anwendungen / Applications

An den MICRONOR MRAD Messrad Arm können alle handelsüblichen Drehgeber und Messräder montiert werden. Weiter haben wir eine grosse Auswahl an Messrädern für alle Anwendungen in unserem Sortiment. Weiter können wir in kurzer Zeit spezielle Messräder nach Ihren Anforderungen herstellen.

The MICRONOR MRAD arm fits all commercially available encoders and measuring wheels. Further, we offer a wide range of standard measuring wheels for adapting to different materials.

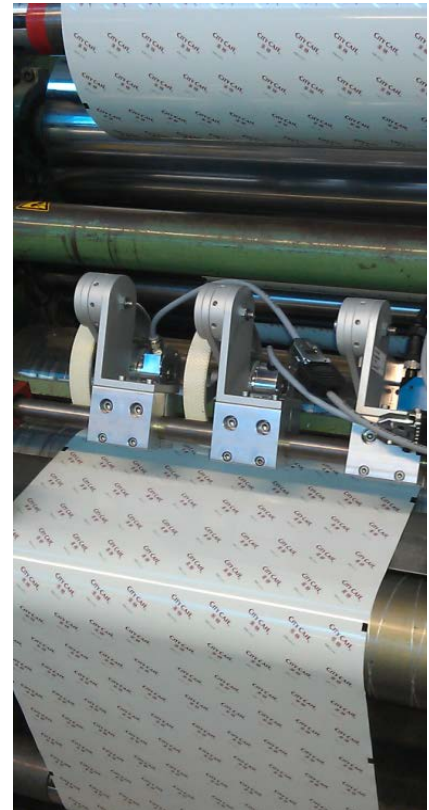
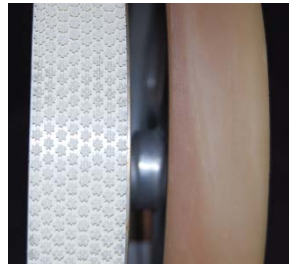

Das Messrad kann in allen Lagen einfach montiert werden.

The wheel can be installed in different orientations.



Montage hängend  
Installation hanging



Montage Seite  
Installation on page



Montage oben  
Installation top

Subject to change without prior notice

MRAD Data Sheet, Document 98-MRAD-01, Revision C, Released 16-May-2023

MICRONOR AG

Switzerland

+41-44-843-4020

www.micronor.ch

sales@micronor.ch

MICRONOR SENSORS INC.

Ventura, CA USA

+1-805-389-6600

www.micronor.com

sales@micronor.com

Model 8400.00.020

Massbild / Outline drawing

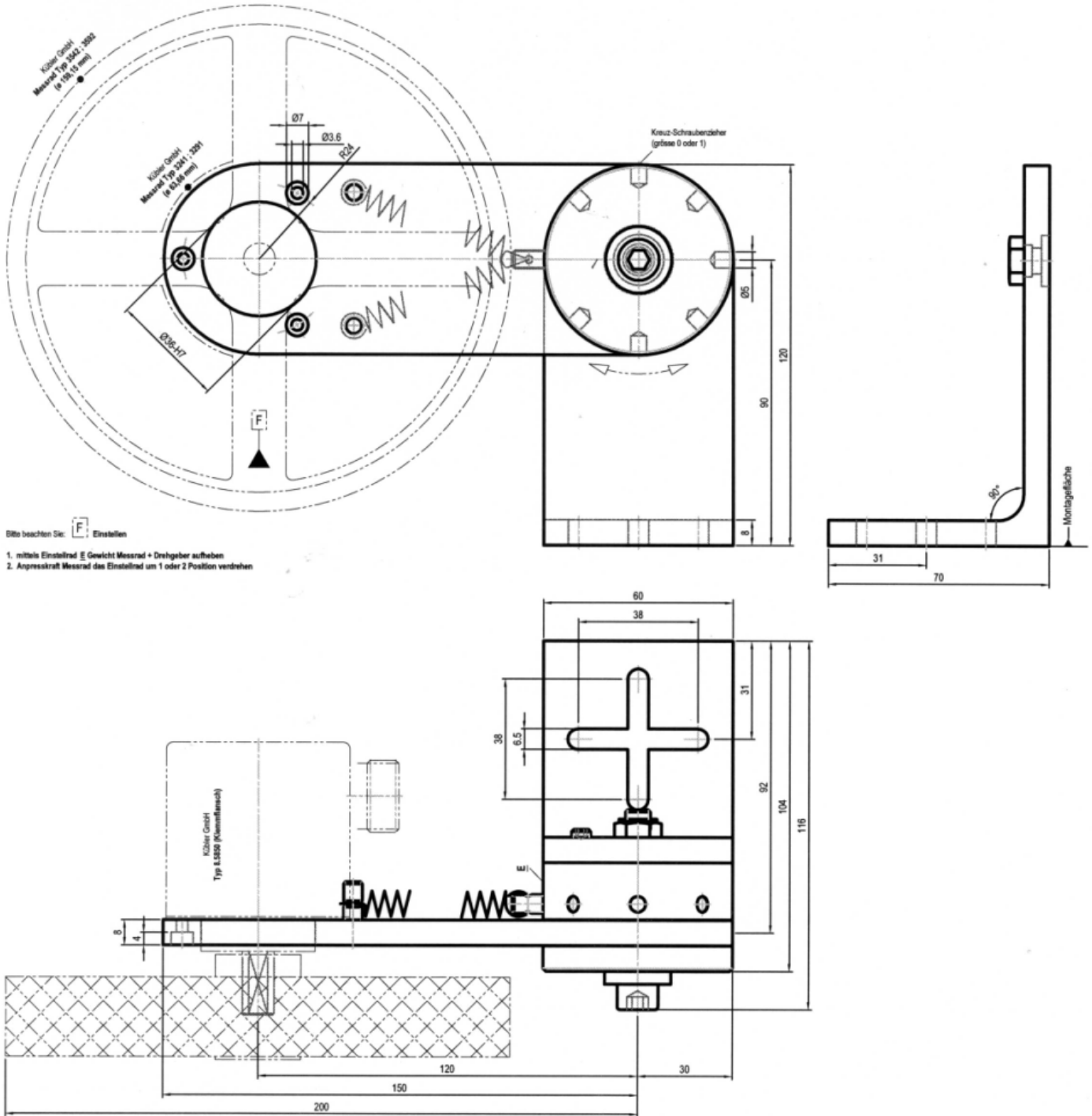

M  
Dk

Model 8400.00.020

Montage / Installation

1. Zentrale Schraube lösen / Loosen central screw

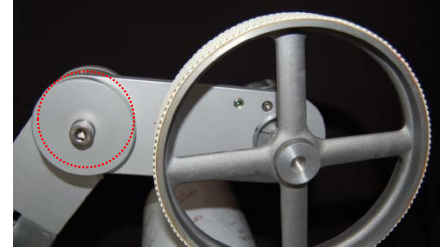
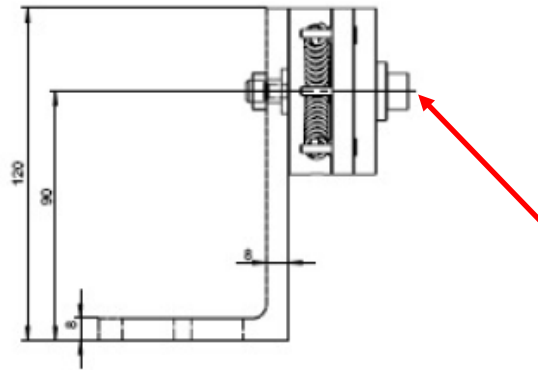

2. Messarm an der gewünschten Stelle mit den mitgelieferten Schrauben montieren.  
Install measuring arm in the desired position with the delivered screws.

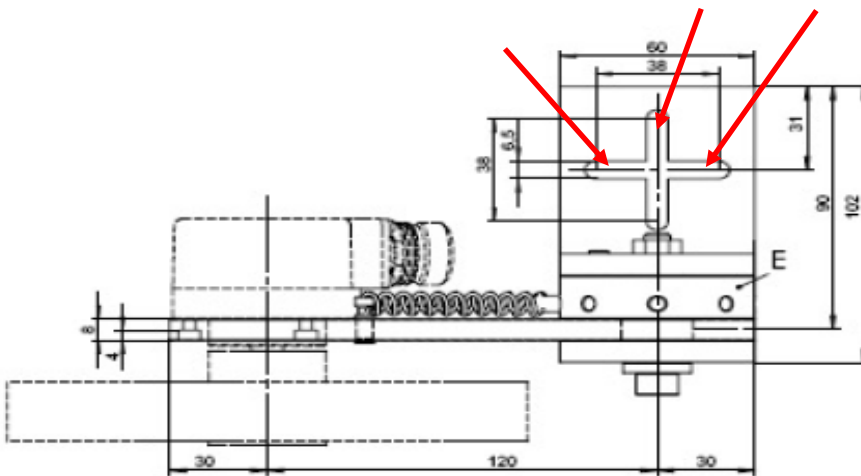

3. Messrad an das zu messende Objekt anlehnen und die zentrale Schraube leicht anziehen.

Lean the measuring wheel against the desired object and fix the central screw.

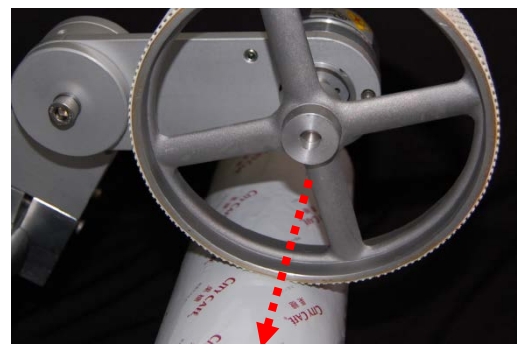

**Model 8400.00.020**

4. Mit Schraubenzieher den Schraubendreher um eine Position drehen (Druck auf das zu messende Objekt wird grösser). Die Zentrale Schraube fest anziehen.

Turn with a screwdriver the screw wheel around for one position (the pressure on the object will be more strictly). Now, you have to fix the central screw.

**1** = Einstellen mit Schraubendreher / Adjust with screw wheel

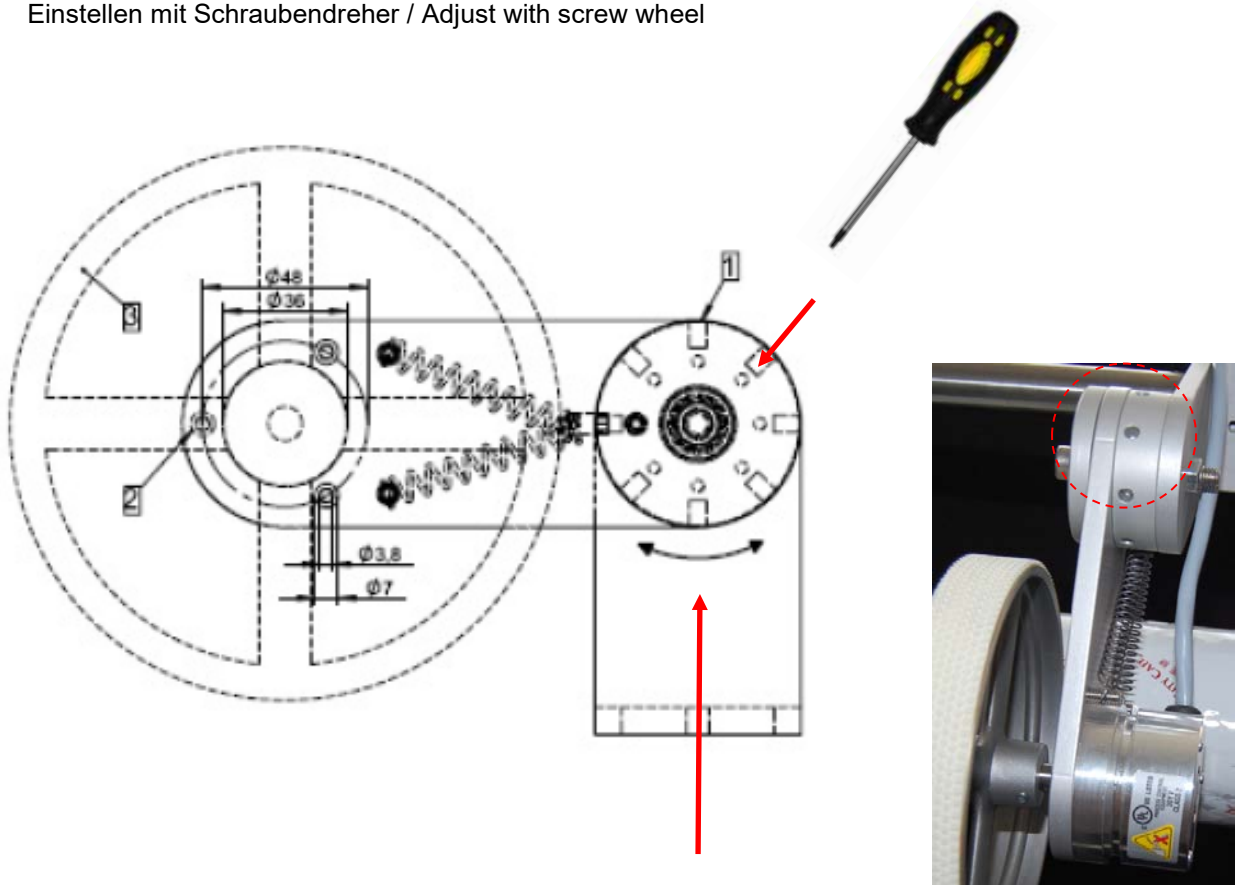

5. Messarm mit Messrad mit dem richtigen Anpressdruck ist funktionsbereit / Measuring arm with measuring wheel with the correct contact pressure is now operational.

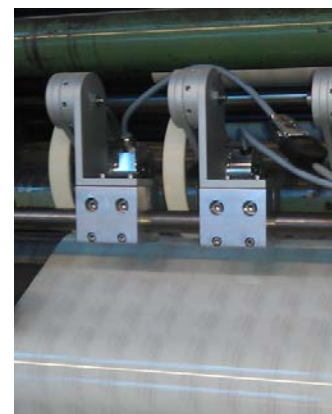

**Model 8400.00.020**

**Montage Kurzfassung**

**Montage:**

- a) Halter montieren: Federarm mittels Kreuzschlitznut an Maschine so befestigen, dass der bewegliche Arm parallel zur Laufrichtung ist. Geber an Federarm montieren und elektrischen Anschluss so anbringen, dass der Arm in der Bewegung nicht eingeschränkt ist und keine Zugkraft auf ihn wirkt.
- b) Anpressdruck einstellen: Zentralschraube mit Imbusschlüssel lösen und Arm in ungefähr richtige Position bringen. Mit z.B. Schraubendreher in vorgesehene Bohrung 1 in Einstellrad E eingreifen und Arm so einstellen, dass das Messrad das Messgut berührt. Den Anpressdruck durch Verdrehen des Einstellrads E um etwa eine Raste (~10...30N) einstellen. Zentralschraube wieder festziehen.

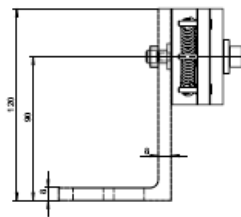
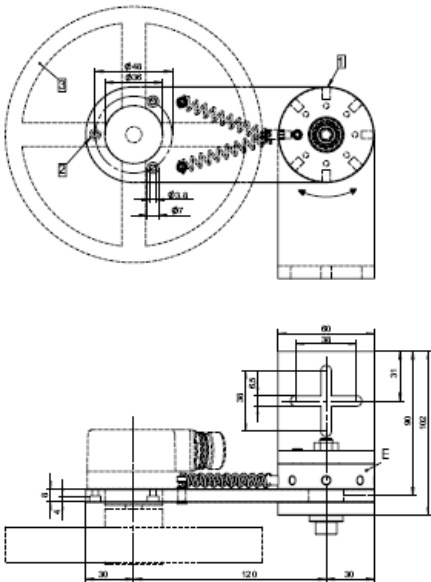

- 1 Einstellen mit Schraubendreher Größe 0 oder 1  
Set using a size 0 or size 1 screwdriver  
Réglage à l'aide du tournevis. Taille 0 ou 1
- 2 3 Stk. Schrauben M3 x 8 DIN 912 beigelegt  
3 M3 x 8 screws DIN 912 enclosed  
3 vis M3 x 8 DIN 912 jointes
- 3 Messrad / Measuring wheel / Roue de mesure

**Hinweis:**

Arm so montieren, dass das Messrad parallel zum Messgut läuft. Anpressdruck so einstellen, dass das Messgut nicht beschädigt wird.

**Wartung:**

Leichtgängigkeit des Arms regelmässig prüfen. Bei Schwergängigkeit zur Reinigung/Wartung einsenden.

**Technische Daten:**

Anpressdruck je Raste: ca. 20N (Erste Raste zwischen 0 und ca. 20N)  
Temperatur: -40°C ... +120°C

Model 8400.00.020

Mounting short Form

Mounting:

- a) Mount holder: Fasten flexible arm to the machine by means of the crossrecess groove in such a way that the mobile arm is in parallel to the running direction. Mount transducer on the flexible arm establish the electric connection in such a way that the arm is not restricted in its travel and not subject to any tensile force.
- b) Set contact pressure: Loosen flexible screw using an Allen key and bring arm in approximately the correct position. Engage, for example, a screwdriver in the provided bore 1 in the setting wheel E and adjust arm such that the measuring wheel makes contact with the object to be measured. Set the contact pressure by turning the setting wheel E about one notch (~10...30N) Re-tighten central screw.

Note:

Mount arm such that the measuring wheel runs in parallel to the object to be measured. Set contact pressure to a value that will not damage the object to be measured.

Maintenance:

Ensure smooth running of the arm by regular checks. If running becomes sluggish, send in for cleaning/maintenance.

Technical Data:

Contact pressure per notch:  
approx. 20N (first notch  
between 0 and approx. 20N)

Temperature: -40°C ...  
+120°C

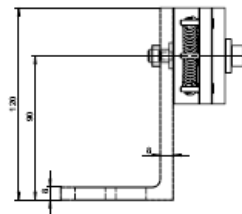
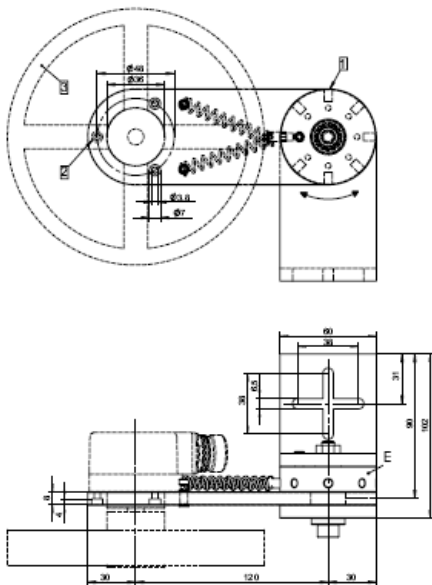

- 1 Einstellen mit Schraubendreher Größe 0 oder 1  
Set using a size 0 or size 1 screwdriver  
Réglage à l'aide du tournevis. Taille 0 ou 1
- 2 3 Stk. Schrauben M3 x 8 DIN 912 beigelegt  
3 M3 x 8 screws DIN 912 enclosed  
3 vis M3 x 8 DIN 912 jointes
- 3 Messrad / Measuring wheel / Roue de mesure

**Model 8400.00.020**

**Ordering Numbers**

NOTE: A complete measuring wheel system consists of arm, wheel and encoder

**For Measuring Wheel Applications Using Standard Size 58mm Optical Encoder**

**8400.00.020** MRAD Measuring arm (MARM), For use with Size 58mm optical encoders with clamping flange mount, Ø10mm Shaft

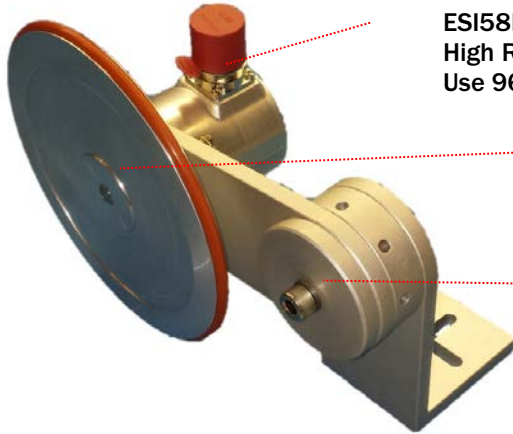

**ESI58HA.1265.36000**  
**High Resolution Incremental Encoder, 36'000ppr, Ø10mm shaft**  
 Use 9600.00.104 High Temperature Cable Assembly

**EC-TD5350-10MM**  
**MRAD.599 High Temperature 0.5m Wheel, Ø10mm bore**

**8400.00.020**  
**Adjustable Spring-Loaded MRAD Arm (MARM)**

**ESI58HA.1265.36000** High Resolution Incremental Encoder, 36'000 ppr resolution, +10..30 VDC, A/A'/B/B'/Z/Z' push-pull outputs  
**9600.06.104** High Temperature Encoder Cable Assembly, 15m, One end terminated with DIN M23 connector straight plug

<b>8400.55.101</b>	MRAD.512, Wheel with diamond knurl surface finish	For cardboard, wood and textile
<b>8400.55.111</b>	MRAD.542, Wheel with smooth PUR coating	For plastic, paper, cardboard and wood
<b>8400.00.121</b>	MRAD.562, Wheel with tufted rubber PUR coating	For textile, bare metals and varnished surfaces
<b>8400.00.131</b>	MRAD.592, Wheel with ribbed PUR coating	For textile

**EC-TD5350-10MM** MRAD.599, Wheel with high temp silicone rubber o-ring tread (replaceable) For monitoring electrode position in smelters

**NOTE: The high temperature silicone rubber o-ring tread used on the MRAD.599/EC-TD5350-XX High Temperature Wheels is replaceable and can be ordered as EC-TD5350-ORING. A VITON O-ring version is available as EC-TD5350-VITON.**

**For Measuring Wheel Applications Requiring Fiber Optic Encoder**

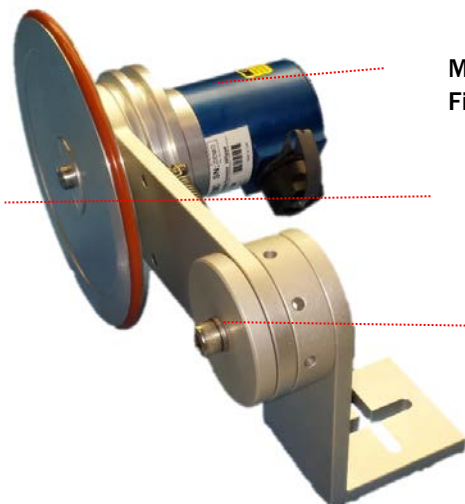

**MR326-D12D00**  
**Fiber Optic Incremental Encoder, 360ppr, Ø12mm shaft**

**EC-TD5350-12MM**  
**MRAD.599 High Temp 0.5m Wheel, Ø12mm bore**

**9350.02.093**  
**Adjustable Spring-Loaded MRAD Arm (MARM)**

**9350.02.093** MRAD Measuring arm (MARM), For use with MR326 series Fiber Optic Encoder, 360ppr, Ø12mm Shaft

<b>9350.02.095</b>	MRAD.562, Ø12mm bore, Wheel with tufted rubber coating	For textile, bare metals and varnished surfaces
<b>EC-TD5350-12MM</b>	MRAD.599, Ø12mm Bore, Wheel with high temp silicone rubber o-ring tread	For monitoring electrode position in smelters

<b>MR346-D12D00</b>	MR326 Fiber Optic Incremental Encoder, 360 ppr resolution, ODVA IP-LC interface	For use with 9350.02.093 MARM
<b>MR346-D12C1R5</b>	MR326 Fiber Optic Incremental Encoder, 360 ppr resolution, 1.5m LC Dupelx Pigtail	For use with 9350.02.093 MARM

**MR320** Controller for use with MR320 series fiber optic incremental encoders, Features both RS422 and Push-pull quadrature outputs

*Subject to change without prior notice* MRAD Data Sheet, Document 98-MRAD-01, Revision C, 16-May-2023 7