

# Rotary Measuring Technology

## Absolute singleturn encoder hollow shaft version

**MICRONOR**  
automation components

### Universal Type ENA 58



- SSI or parallel interface
- Highest shock resistance on the market ( $\geq 2500 \text{ m/s}^2$ , 6 ms acc. to DIN IEC 68-2-27)
- Divisions: up to 16384 (14 bits), singleturn
- Housing  $\varnothing$  58 mm
- IP 66
- Various options (e.g. LATCH, SET...)
- Gray, Binary or BCD code
- Temperature and ageing compensation
- Short-circuit proof outputs
- Integrative Technology®  
Patented new type of construction integrates all components; use of an opto-asic and 6-layer multilayer technology now on just a single PCB
- resolution up to 14 bits.
- available as explosion proof zone 2 and 22

#### Mechanical characteristics:

Speed without sealing:	max. 12000 min <sup>-1</sup>
Speed with sealing <sup>1)</sup> :	max. 6000 min <sup>-1</sup>
Rotor moment of inertia:	approx. $6 \times 10^{-6} \text{ kgm}^2$
Starting torque with sealing:	< 0.05 Nm
Weight:	approx. 0.4 kg
Protection acc. to EN 60 529 with sealing:	IP 66
Working temperature without sealing:	-20° C ... +85 °C <sup>2)3)</sup>
Working temperature with sealing:	-20° C ... +80 °C <sup>2)3)</sup>
Operating temperature without sealing:	-20° C ... +90 °C <sup>2)4)</sup>
Operating temperature with sealing:	-20° C ... +85 °C <sup>2)4)</sup>
Shaft:	stainless steel H7
Shock resistance acc. to DIN-IEC 68-2-27	2500 m/s <sup>2</sup> , 6 ms
Vibration resistance acc. to DIN-IEC 68-2-6:	100 m/s <sup>2</sup> , 10...2000 Hz

<sup>1)</sup> For continuous operation max. 1500 min<sup>-1</sup>

<sup>2)</sup> Non-condensing

<sup>3)</sup> 70 °C with cable

<sup>4)</sup> 80 °C with cable

#### Divisions and code types available at short notice

Gray/Binary

250, **360**, 500, **720**, 900, **1000**, **1024** (10 Bit), 1250, 1440, 1800, 2000, 2500, 2880, **3600**, 4000, **4096** (12 Bit), 5000, 7200, **8192** (13 Bit), **16384** (14 Bit)

BCD

250, **360**, 500, **720**, 900, **1000**, **1024** (10 Bit), 1250, 1440, 1800, 2000

Other on request

#### Preferred divisions are bold

(reduced delivery time)

#### Electrical characteristics:

Interface type:	Synchronous Serial (SSI)	Synchronous Serial (SSI)	Parallel	Parallel
Supply voltage (U <sub>B</sub> ):	5 V DC (± 5 %)	10 ... 30 V DC	5 V DC (± 5 %)	10 ... 30 V DC
Output driver:	RS 485	RS 485	Push-pull	Push-pull
Current consumption typ.:	89 mA	89 mA	109 mA	109 mA
(no load) max.:	138 mA	138 mA	169 mA	169 mA
Permissible load/channel:	max. +/- 20 mA	max. +/- 20 mA	max. +/- 10 mA	max. +/- 10 mA
SSI pulse rate min./max.:	100 kHz/500 kHz	100 kHz/500 kHz	-	-
Signal level high:	typ. 3.8 V	typ. 3.8 V	min. 3.4 V	min. U <sub>B</sub> - 2.8 V
Signal level low (I <sub>Load</sub> = 20 mA):	typ. 1.3 V	typ. 1.3 V	-	-
(I <sub>Load</sub> = 10 mA):	-	-	max. 1.5 V	max. 1.8 V
(I <sub>Load</sub> = 1 mA):	-	-	max. 0.3 V	-
Rise time t <sub>r</sub> (without cable):	max. 100 ns	max. 100 ns	max. 0.2 μs	max. 1 μs
Fall time t <sub>f</sub> (without cable):	max. 100 ns	max. 100 ns	max. 0.2 μs	max. 1 μs
Short circuit proof outputs: <sup>1)</sup>	yes	yes <sup>2)</sup>	yes	yes
Reverse connection protection at U <sub>B</sub> :	no	yes	no	yes
Conforms to CE requirements acc. to EN 61000-6-1, EN 61000-6-4 and EN 61000-6-3				

<sup>1)</sup> If supply voltage correctly applied

<sup>2)</sup> Only one channel allowed to be shorted-out:

(If U<sub>B</sub>=5 V, short-circuit to channel, 0 V, or +U<sub>B</sub> is permitted)

(If U<sub>B</sub>=5-30 V, short-circuit to channel or 0 V is permitted)

### Universal Type ENA 58

#### Control Inputs

##### Up/down input to switch the counting direction

By default, if glancing at the shaft side, absolute encoders deliver increasing code values when shaft rotates clockwise (cw). When the shaft rotates counter-clockwise (ccw), the output delivers accordingly decreasing code values.

As long as the Up/down input receives the corresponding signal (high), this feature is reversed. Clockwise rotation delivers decreasing code values while counter-clockwise rotation delivers increasing code values.

The response time is :       for 5 V DC supply voltage, 0.4 ms  
                                          for 10 ... 30 V DC supply voltage, 2 ms.

##### SET input

This input is used to reset (to zero) the encoder. A control pulse (high) sent to this input allows storing the current position value as new zero position in the encoder.

##### Note :

Before activating the SET input after supplying the encoder with the supply voltage, a counting direction (cw or ccw) must be clearly defined on the Up/down input!

The response time is :       for 5 V DC supply voltage, 0.4 ms  
                                          for 10 ... 30 V DC supply voltage, 2 ms.

##### LATCH input

This input is used to „freeze“ the current position value. The position value will be statically available on the parallel output as long as this input will remain active (high).

The response time is :       for 5 V DC supply voltage, 140  $\mu$ s,  
                                          for 10 ... 30 V DC supply voltage, 200  $\mu$ s.

#### Switching level of the control inputs:

Supply voltage	5 V DC	10 ... 30 V DC
low	$\leq 1.7$ V	$\leq 4.5$ V
high	$\geq 3.4$ V	$\geq 8.7$ V



# Rotary Measuring Technology

## Absolute singleturn encoder hollow shaft version

### Universal Type ENA 58

#### Dimensions

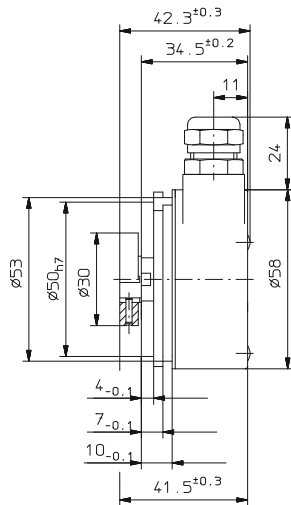

#### Bracket type 1

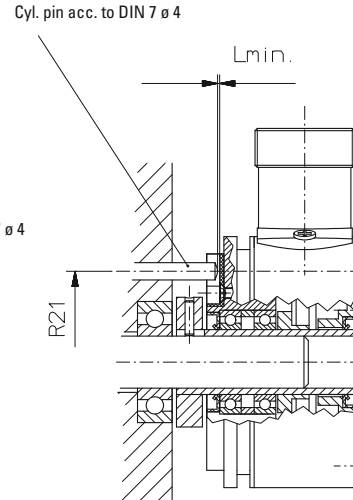
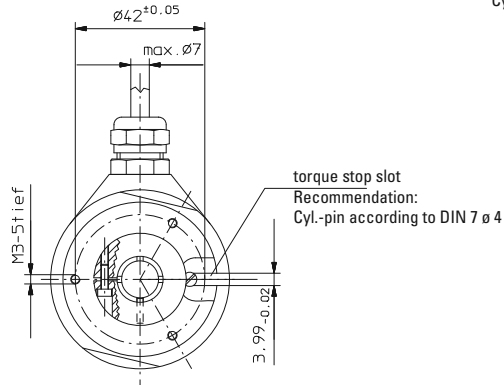

#### Bracket type 3 with stator coupling

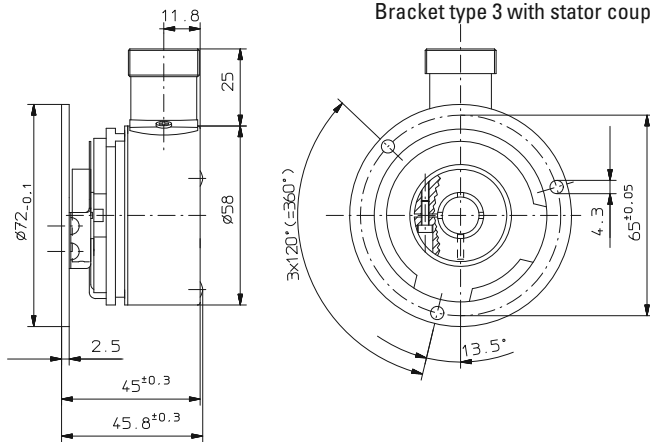

#### Mounting advice:

- 1) The flanges and shafts of the encoder and drive should not both be rigidly coupled together at the same time.
- 2) When mounting a hollow shaft encoder, we recommend using a torque stop pin or a stator coupling.
- 3) When mounting the encoder ensure that the dimension Lmin. is larger than the maximum axial play of the drive. Otherwise there is a danger that the device could mechanically seize up.

# Rotary Measuring Technology

## Absolute singleturn encoder hollow shaft version

### Universal Type ENA 58

Order code:

ENA 58.XXXX.XXXX

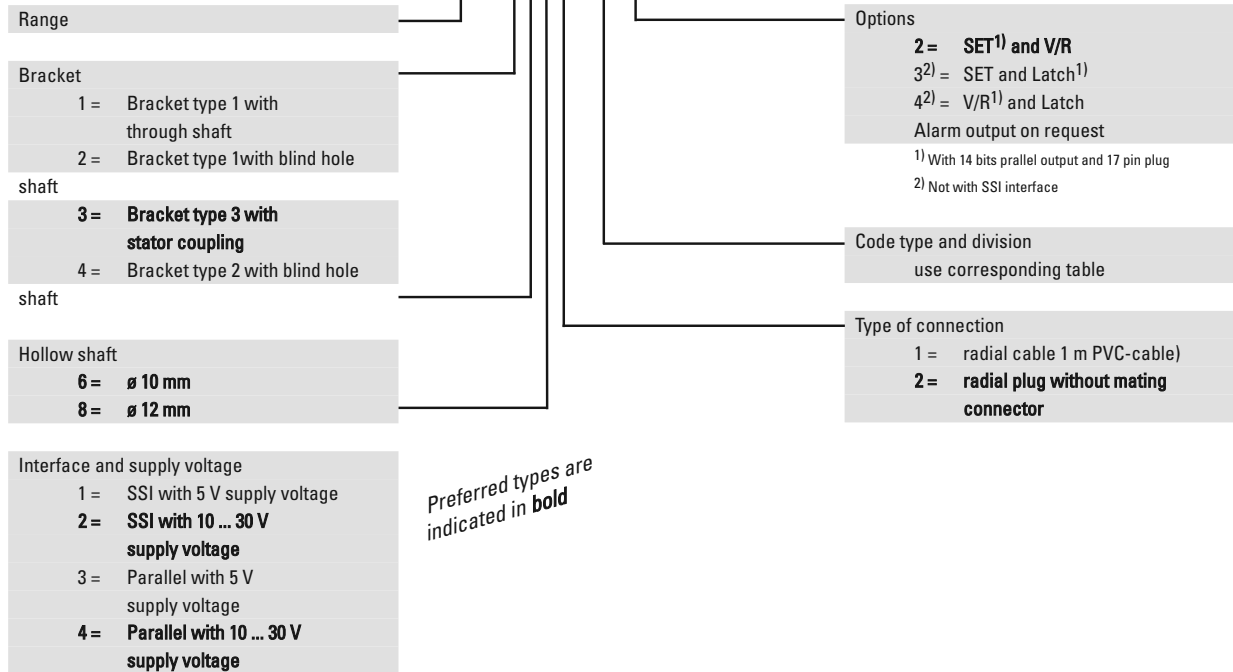

#### Code type and division with parallel output

Interface and supply voltage, version 3 or 4 (Parallel):

Division	Order code Gray/Gray-Excess	Order code Binary	Order code BCD
250	E02	B02	D02
<b>360<sup>1)</sup></b>	<b>E03</b>	B03	D03
500	E05	B05	D05
<b>720<sup>1)</sup></b>	<b>E07</b>	B07	D07
900	E09	B09	D09
<b>1000<sup>1)</sup></b>	<b>E01</b>	B01	D01
<b>1024 (10 Bits)</b>	<b>G10</b>	<b>B10</b>	D10
1250	E12	BA2	DA2
1440	E14	BA1	DA1
1800	E18	B18	D18
2000	E20	B20	D20
2500	E25	B25	
2880	E28	B28	
3600 <sup>1)</sup>	E36	B36	
4000	E40	B40	
<b>4096 (12 Bits)</b>	<b>G12</b>	<b>B12</b>	
5000	E50	B50	
7200	E72	B72	
<b>8192 (13 Bits)</b>	<b>G13</b>	<b>B13</b>	
<b>16384 (14 Bit)</b>	<b>G14</b>	<b>B14</b>	

Preferred divisions are bold

#### Code type and division for encoder with SSI-Output

Interface and supply voltage, version 1 or 2 (SSI):

Division	Order code Gray	Order code Binary
1024 (10 Bit)	G10	B10
4096 (12 Bit)	G12	B12
8192 (13 Bit)	G13	B13
16384 (14 Bit)	G14	B14

# Rotary Measuring Technology

## Absolute singleturn encoder shaft version

**MICRONOR**  
automation components

### Universal Type ESA 58



- Highest shock resistance on the market ( $\geq 2500 \text{ m/s}^2$ , 6 ms acc. to DIN IEC 68-2-27)
- SSI, parallel or current (4 ... 20 mA) interface
- Divisions: up to 16384 (14 bits), singleturn
- Housing  $\varnothing$  58 mm
- IP 65
- Various options (e.g. LATCH, SET...)
- Gray, Binary or BCD code
- Temperature and ageing compensation
- Short-circuit proof outputs
- Patented new type of construction integrates all components; use of an opto-asic and 6-layer multilayer technology now on just a single PCB with resolution of up to 14 bits.
- 4 ... 20 mA output
-  available as explosion proof zone 2 and 22

#### Mechanical characteristics:

Speed:	max. $12000 \text{ min}^{-1}$
Rotor moment of inertia:	approx. $1.8 \times 10^{-6} \text{ kgm}^2$
Starting torque:	< 0.01 Nm
Radial load capacity of shaft:	80 N
Axial load capacity of shaft:	40 N
Weight:	approx. 0.4 kg
Protection acc. to EN 60 529:	IP 65
Working temperature:	$-20^\circ \text{C} \dots +85^\circ \text{C}^{1)}$
Operating temperature:	$-20^\circ \text{C} \dots +90^\circ \text{C}^{1)}$
Shaft:	stainless steel
Shock resistance acc. to DIN-IEC 68-2-27	$2500 \text{ m/s}^2$ , 6 ms
Vibration resistance acc. to DIN-IEC 68-2-6:	$100 \text{ m/s}^2$ , 10...2000 Hz

<sup>1)</sup>  $80^\circ \text{C}$  with cable

<sup>2)</sup> Non-condensing

#### Divisions and code types available at short notice

Gray/Binary

250, **360**, 500, **720**, 900, **1000**,  
**1024** (10 Bit), 1250, 1440, 1800, 2000, 2500,  
2880, **3600**, 4000, **4096** (12 Bit), 5000, 7200,  
**8192** (13 Bit), **16384** (14 Bit)

BCD

250, **360**, 500, **720**, 900, **1000**,  
**1024** (10 Bit) 1250, 1440, 1800, 2000  
Other on request

**Preferred divisions are shown in bold**  
(reduced delivery time).

#### Electrical characteristics SSI or parallel interface:

Interface type:	Synchronous Serial (SSI)	Synchronous Serial (SSI)	Parallel	Parallel
Supply voltage ( $U_B$ ):	5 V DC ( $\pm 5\%$ )	10 ... 30 V DC	5 V DC ( $\pm 5\%$ )	10 ... 30 V DC
Output driver:	RS 485	RS 485	Push-pull	Push-pull
Current consumption typ.:	89 mA	89 mA	109 mA	109 mA
(no load) max.:	138 mA	138 mA	169 mA	169 mA
Permissible load/channel:	max. +/- 20 mA	max. +/- 20 mA	max. +/- 10 mA	max. +/- 10 mA
SSI pulse rate min./max.:	100 kHz/500 kHz	100 kHz/500 kHz	-	-
Signal level high:	typ. 3.8 V	typ. 3.8 V	min. 3.4 V	min. $U_B - 2.8 \text{ V}$
Signal level low ( $I_{Load} = 20 \text{ mA}$ ):	typ. 1.3 V	typ. 1.3 V	-	-
( $I_{Load} = 10 \text{ mA}$ ):	-	-	max. 1.5 V	max. 1.8 V
( $I_{Load} = 1 \text{ mA}$ ):	-	-	max. 0.3 V	-
Rise time $t_r$ (without cable):	max. 100 ns	max. 100 ns	max. 0.2 $\mu\text{s}$	max. 1 $\mu\text{s}$
Fall time $t_f$ (without cable):	max. 100 ns	max. 100 ns	max. 0.2 $\mu\text{s}$	max. 1 $\mu\text{s}$
Short circuit proof outputs: <sup>1)</sup>	yes	yes <sup>2)</sup>	yes	yes
Reverse connection protection at $U_B$ :	no	yes	no	yes
Conforms to CE requirements acc. to EN 61000-6-1, EN 61000-6-4 and EN 61000-6-3				

<sup>1)</sup> During the run-in-phase of approx. 2 seconds, reduce the limits for working temperature<sub>max</sub> or speed<sub>max</sub> by 1/3

<sup>2)</sup> Dependent on the shaft diameter

### Universal Type ESA 58

#### Electrical characteristics current interface 4 ... 20 mA

##### Sensor part

Interface type:	4 ... 20 mA	4 ... 20 mA
Supply voltage (U <sub>B</sub> ):	10 ... 30 V DC	5 V DC
Current consumption typ.:	70 mA	70 mA
(no load) max.:	84 mA	84 mA
Word change frequency:	max. 15.000/s	max. 15.000/s

##### Current loop

Supply voltage (U <sub>s</sub> ):	10 ... 30 V DC
Analogue signal:	4 ... 20 mA
max. input resistance of the input circuit:	200 Ω (U <sub>s</sub> = 10 V), 1 kΩ (U <sub>s</sub> = 30 V)
Measuring range:	0 ... 360 °
Max. Failure (25 °C):	0.2 °
Resolution:	13 Bit
Building up time:	max. 2 ms
Temperature coefficient:	0.1°/10 K
Current if detector error:	≤ 3.5 mA
Sensor and current loop are galvanically insulated	
Conforms to CE requirements acc. to EN 61000-6-1, EN 61000-6-4 and EN 61000-6-3	

#### Control inputs:

##### Up/down input to switch the counting direction

By default, if glancing at the shaft side, absolute encoders deliver increasing code values when shaft rotates clockwise (cw). When the shaft rotates counter-clockwise (ccw), the output delivers accordingly decreasing code values. The same applies to models with current interfaces. When the shaft rotates clockwise, the output delivers increasing current values, and decreasing values when it rotates counter-clockwise.

As long as the Up/down input receives the corresponding signal (high), this feature is reversed. Clockwise rotation will deliver decreasing code/current values while counter-clockwise rotation will deliver increasing code/current values.

The response time is :  
for 5 V DC supply voltage, 0.4 ms  
for 10-30 V DC supply voltage, 2 ms.

##### Switching level of the control inputs:

Supply voltage:	5 V DC	10 ... 30 V DC
low	≤ 1.7 V	≤ 4.5 V
high	≥ 3.4 V	≥ 8.7 V

##### SET input

This input is used to reset (to zero) the encoder. A control pulse (high) sent to this input allows storing the current position value as new zero position in the encoder.

For models equipped with a current interface, the analogue output (4 ... 20 mA) will be set accordingly to the value 4 mA.

Note : before activating the SET input after supplying the encoder with the supply voltage, a counting direction (cw or ccw) must be defined univocally on the Up/down input!

The response time is :  
for 5 V DC supply voltage, 0.4 ms  
for 10 ... 30 V DC supply voltage, 2 ms.

##### LATCH input

This input is used to „freeze“ the current position value. The position value will be statically available on the parallel output as long as this input will remain active (high).

The response time is :  
for 5 V DC supply voltage, 140 μs,  
for 10 ... 30 V DC  
supply voltage, 200 μs.



# Rotary Measuring Technology

## Absolute singleturn encoder shaft version

### Universal Type ESA 58

**Dimensions:**

Clamping bracket with Shaft  $\varnothing 10$

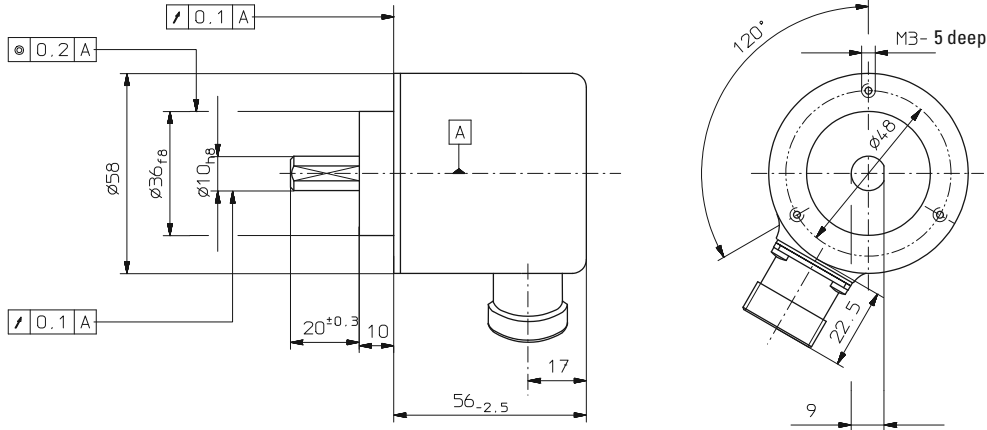

Synchronous bracket with shaft  $\varnothing 6$  mm

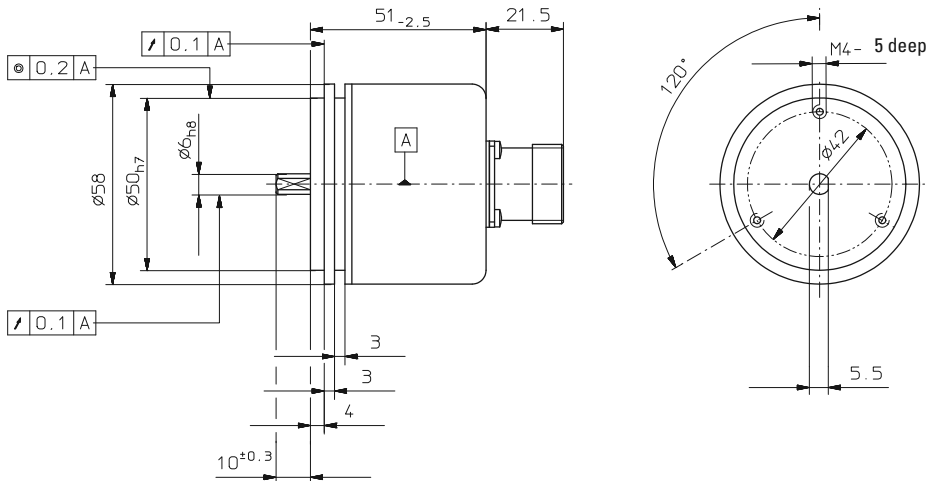

**Top view of mating side, male contact base:**

12 pin plug

17 pin plug

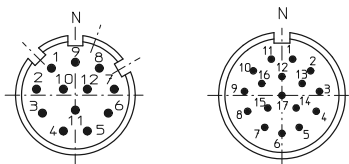

### Universal Type ESA 58

Order code:

ESA 58.XXXX.XXXX

Range	
Bracket	
1 = Clamping bracket	
<b>2 = Synchronous bracket</b>	
Shaft (ø x L)	
<b>1 = ø 6 mm x 10 mm</b>	
2 = ø 10 mm x 20 mm	
Interface and supply voltage	
1 = SSI with 5 V supply voltage	
<b>2 = SSI with 10 ... 30 V supply voltage</b>	
3 = Parallel with 5 V supply voltage	
4 = Parallel with 10 ... 30 V supply voltage	
7 = 4 ... 20 mA with 5 V supply voltage	
<b>8 = 4 ... 20 mA with 10 ... 30 V supply voltage</b>	

*Preferred types are indicated in bold*

Options
<b>2 = SET<sup>1)</sup> and V/R</b>
3 <sup>2)</sup> = SET and Latch <sup>1)</sup>
4 <sup>2)</sup> = V/R <sup>1)</sup> and Latch
ALARM output on request
<sup>1)</sup> At 14 bits parallel output and 17pin plug
<sup>2)</sup> Not with SSI or current interface
Code type and division use corresponding table
Type of connection
1 = Cable axial (1 m PVC-cable)
2 = Cable radial(1 m PVC-cable)
3 = axial plug without mating connector
<b>5 = radial plug without mating connector</b>

#### Code type and division for encoder with parallel output (Interface and supply voltage, version 3 or 4)

Division	Order code	Order code	Order code
	Gray/Gray-Excess	Binary	BCD
250	E02	B02	D02
<b>360</b>	<b>E03</b>	B03	D03
500	E05	B05	D05
<b>720</b>	<b>E07</b>	B07	D07
900	E09	B09	D09
<b>1000</b>	<b>E01</b>	B01	D01
<b>1024</b> (10 Bit)	<b>G10</b>	<b>B10</b>	D10
1250	E12	BA2	DA2
1440	E14	BA1	DA1
1800	E18	B18	D18
2000	E20	B20	D20
2500	E25	B25	
2880	E28	B28	
<b>3600</b>	<b>E36</b>	B36	
4000	E40	B40	
<b>4096</b> (12 Bit)	<b>G12</b>	B12	
5000	E50	B50	
7200	E72	B72	
<b>8192</b> (13 Bit)	<b>G13</b>	B13	
<b>16384</b> (14 Bit)	<b>G14</b>	<b>B14</b>	

Preferred divisions are bold

#### Code type and division for encoder with SSI output

Interface and supply voltage, version 1 or 2

Division	Order code	Order code
	Gray	Binary
1024 (10 Bit)	G10	B10
4096 (12 Bit)	G12	B12
8192 (13 Bit)	G13	B13
16384 (14 Bit)	G14	B14

#### Code type and division for encoder with analogue output

Interface and supply voltage, version 7 or 8  
(4 ... 20 mA)

8192 (13 Bit)	G13
---------------	-----