

F9J GC BG			
F9J	89G7 F DHC B	85H	5DDFCJ 98
7	I D85HPA CI BHB; D5B9@GND	-198%	F; 6

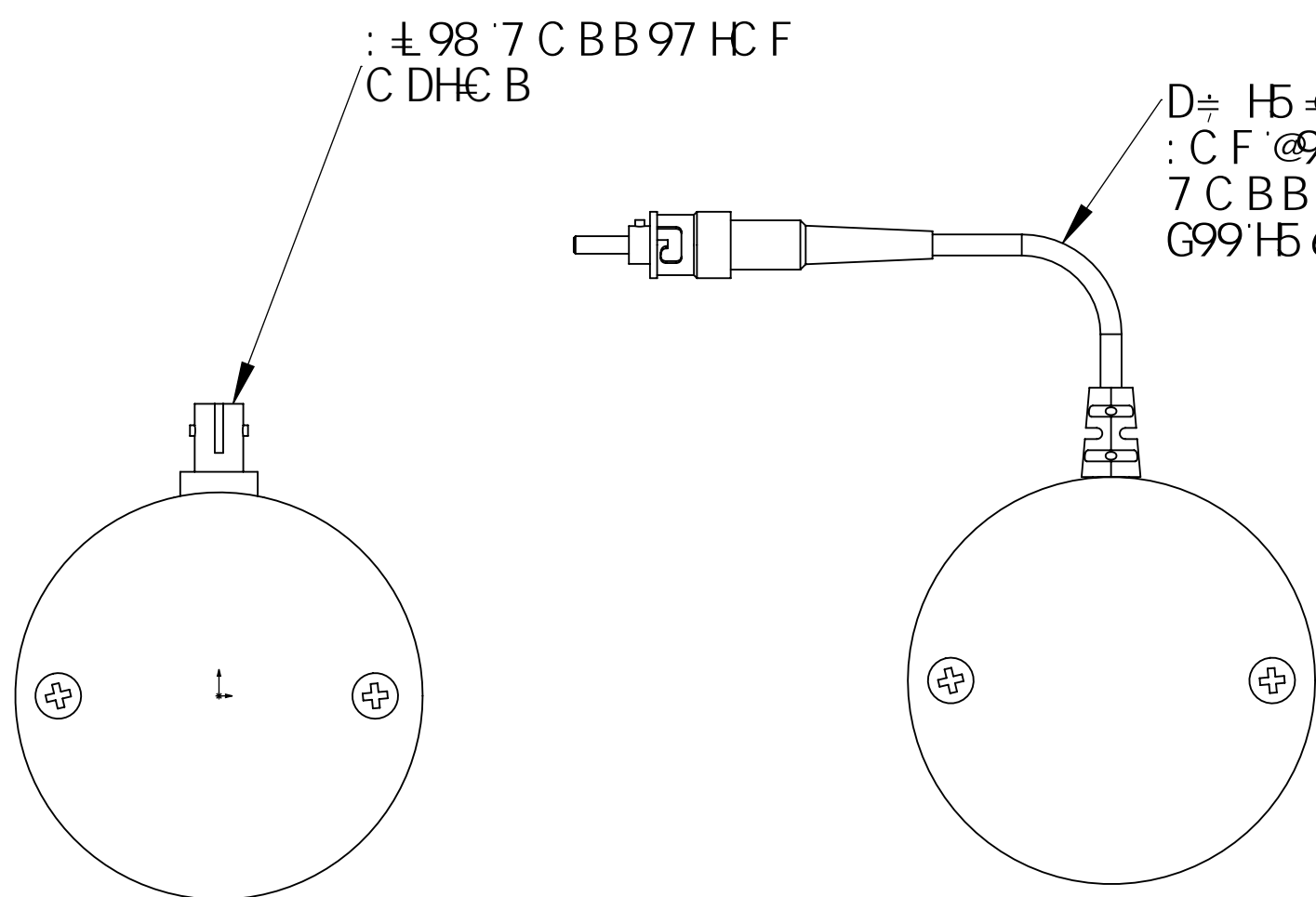

: ± 98 7 C BB 97 HC F
C DHC B

D≠ H5 @C DHC B"
: CF @9B; H< 5B8
7 C BB 97 HC Fž
G99 H5 6@

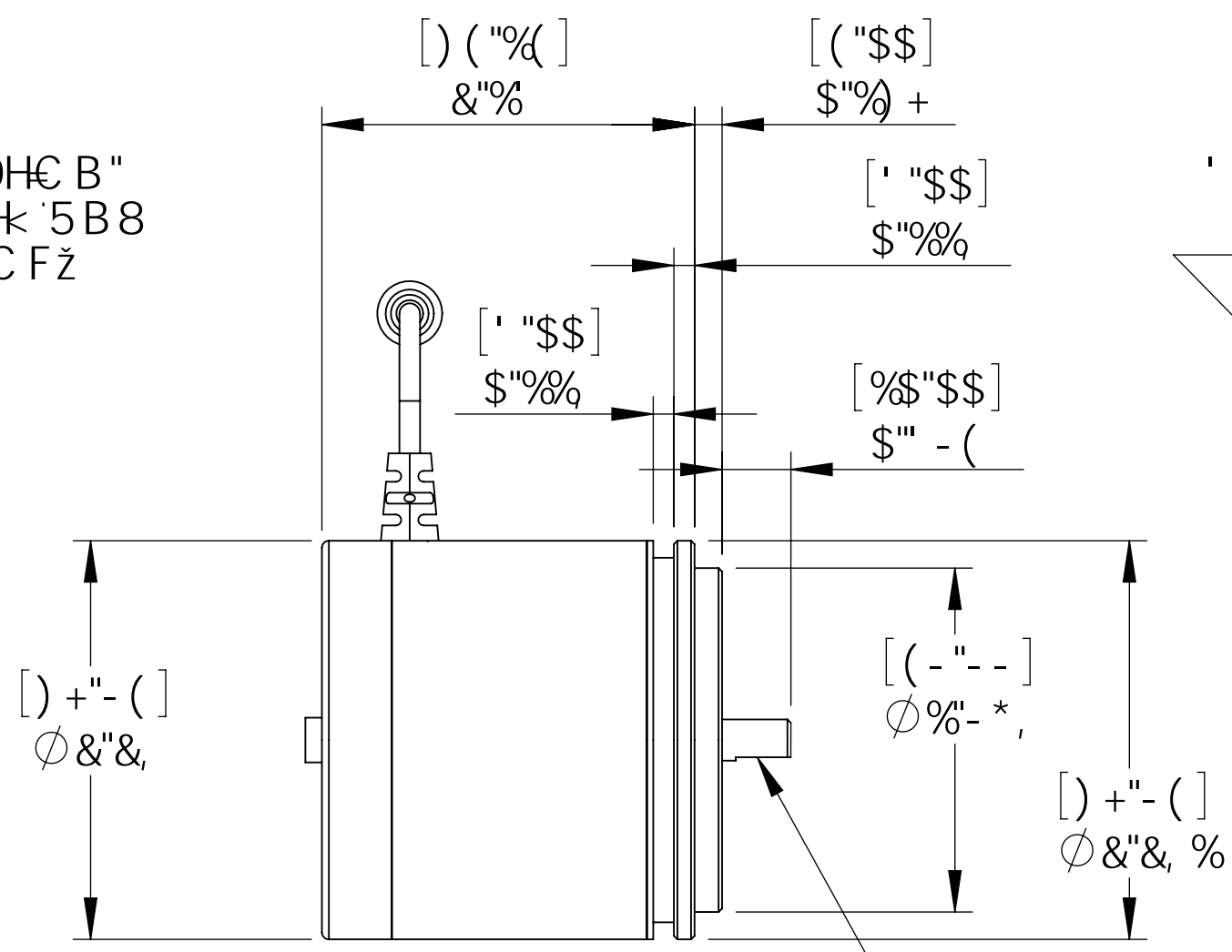

() ("% []
&" % [("\$\$
\$"% @ + [' "\$\$
\$"% % [% "\$\$
\$" - ([("&-
L' Ø "\$%* - H< FI ž
9E GD7 8 5 GG< CK B

' I A (I \$+ ! * < ▽ ' \$" % Q "\$\$Q A B
9E GD7 8 5 GG< CK B

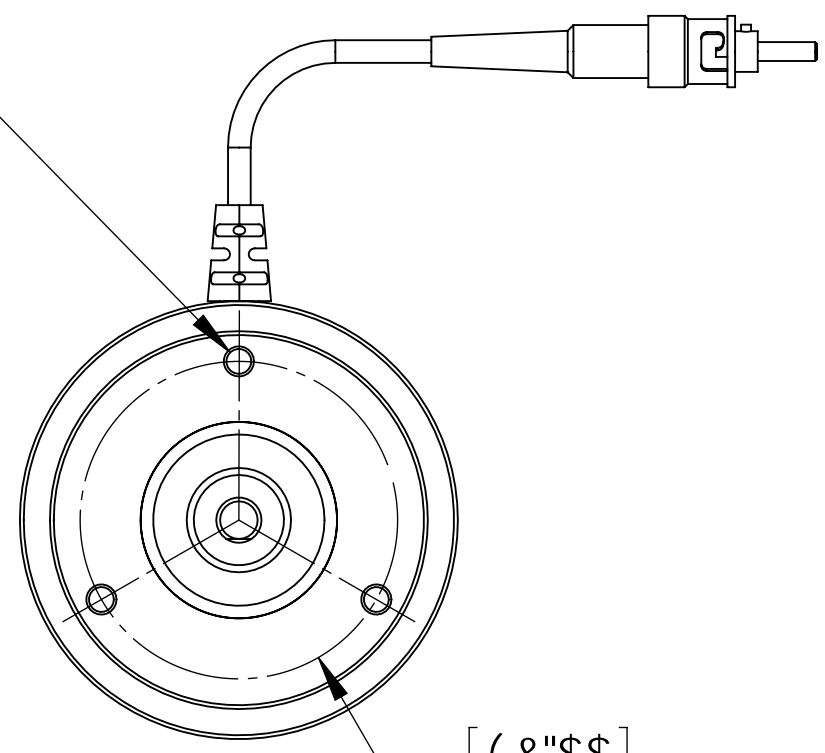

[("\$\$
Ø "%*) (

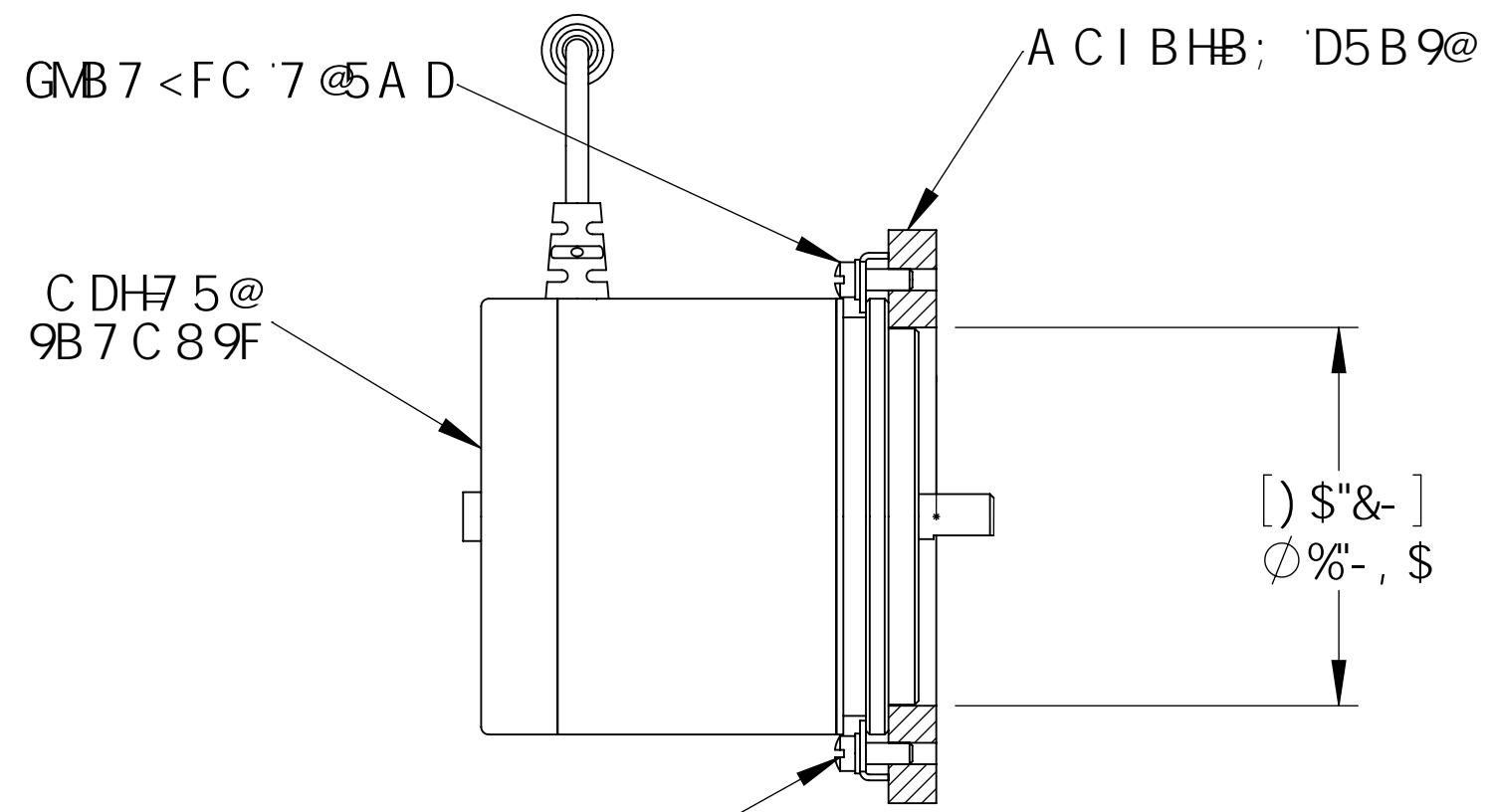

GMB 7 < FC 7 @5 A D

A CI BHB; D5B9@

C DH7 5 @
9B 7 C 8 9F

A CI BHB; D5B9@

: CF G< 5: H8 5 5B8
: @ HGž G99 H5 6@

[) \$"&-]
Ø "%- , \$

[("\$\$
Ø "%*) (

[% "\$)]
Ø "\$+) \$ H< FI A B

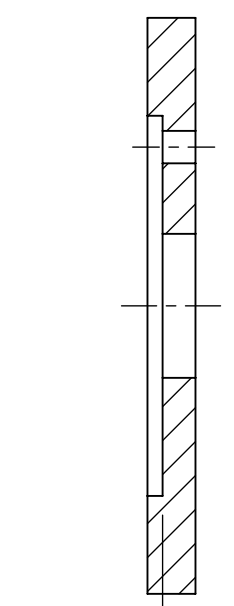

[("\$\$
\$"\$+- 8 99D A B

G97 HC B 6!6

GI ; ; 9GH98 A CI BHB; D5B9@
H< FI !< C @A CI BHK H<
GMB 7 < FC 7 @5 A DG

D5FHBI A 69F C F 8 9F B; 7 C 8 9

A F' %&! 7 * H %F)
A F' %&! 7 * H %\$

GI ; ; 9GH98 A CI BHB; D5B9@
7 CI B H9F! 6C F 98 D5B9@
K H< A CI BHB; G7 F 9K G

" " " K 5FB B; . ? 99D 7 C BB 97 HC F 7 C J 9FG B D @ 7 9
" " " 8 I F B; G H C F 5; 9ž HC DFC H97 H: 69F C DH7
" " " B H9F: 5 7 9G"

&" " K 5FB B; . 8 C B C H 8 F C D I B H " 8 F C D D B;
" " " C F C H 9 F G 9 J 9 F 9 G < C 7 ? A D 5 7 H G
" " " A 5 M 8 5 A 5; 9 I B H "

% " " 5 @ 5 M G I G 9: @ L 6 @ 7 C I D @ B; K < 9 B
" " " A CI BHB; G < 5: H H C 9 L H 9 F B 5 @ 9 E I @ A 9 B H "

BC H 9 G I B @ G G C H 9 F K 6 9 GD 9 7 ÷ 9 8

F 9 G C @ H C B
" " " 5 1 % \$ \$
" " " 6 1 % &
" " " 7 1 & *
" " " 8 1 ' * \$

G < 5: H G N 9 B A @ A 9 H 9 F G
" " " * 1 * A A G < 5: H

" " " f I Ø "\$ &) , + "\$ \$ \$ & Q " - , - ± "\$ \$ \$ Q
" " " K H< "\$ & % * Q ") \$: @ H ž

C H 9 F G < 5: H C D H C B G 5 F 9 5 J 5 @ 5 6 @

D≠ H5 @ @ 9 B; H< B A 9 H 9 F G
" " " F 1 8 9 7 A 5 @ D C B H C
" " " \$ \$ 1 : ± 9 8 7 C B B 9 7 H C F
" " " % F) 1 %) A 9 H 9 F

7 C B B 9 7 H C F H M D 9
" " " H 1 G H

I B @ G C H 9 K @ 9 7 + 9 8	B 5 A 9	8 5 H	A 7 F C B C F B 7 "
" " " 8 A 9 8 G C B G 5 F 9 B	8 F 5 K B	F 6 C M F	B 9 K 6 I F M D 5 F 2 7 5 f i \$) E (- - ! \$ % &)
" " " B 7 < 9 0 A A Q	7 < 9 7 9 8		H H 9
H C @ F 5 B 7 9 G	9 8: 5 D D F "		C D H 7 5 @ 9 B 7 C 8 9 F
5 B: I @ F . ± 7 * H C D 6 5 7 9 8 9 7 A 5 @ ± \$ & H F 9 9 D 6 5 7 9 8 9 7 A 5 @ ± \$ \$ C I F D 6 5 7 9 8 9 7 A 5 @ ± \$ \$ \$	A :: 5 D D F "		G N 9
B H F D F 9 8: 9 C A 9 F 7 H C @ F 5 B 7 9: D F	E 5 "		8 K ; " " B C "
A 5 H F 5 @	7 C A A 9 8 H G		F 9 J
" " " B G:			A F' % &
8 C B C H 7 5 @ 8 F 5 K B:			7
			G 7 5 @ 9 . % % K 9 ÷ < H "
			G < 9 9 H % C : %

D F C D F @ 6 F M 5 8 8 7 C B: 8 9 H 6 @
H 9 B: C F A 5 H C B 7 C B H 5 9 8 B H G
8 F 5 K B: G I H 9 C C 4 9 D F C D F H A C
A 7 F C B C F 7 C F D C F 5 H C B " 5 B M
9 0 F C 8 1 7 H C B B D 5 F H C F 5 G 5 K < C @
K H< C I H H 9 K F H H B D F A G G C B C:
A 7 F C B C F 7 C F D C F 5 H C B G
D F C < 4 H 8