

REVISIONS			
REV.	DESCRIPTION	DATE	APPROVED
A	NEW RELEASE	2-5-13	RGB

FIBER OPTIC CABLE WITH DUPLEX LC CONNECTOR

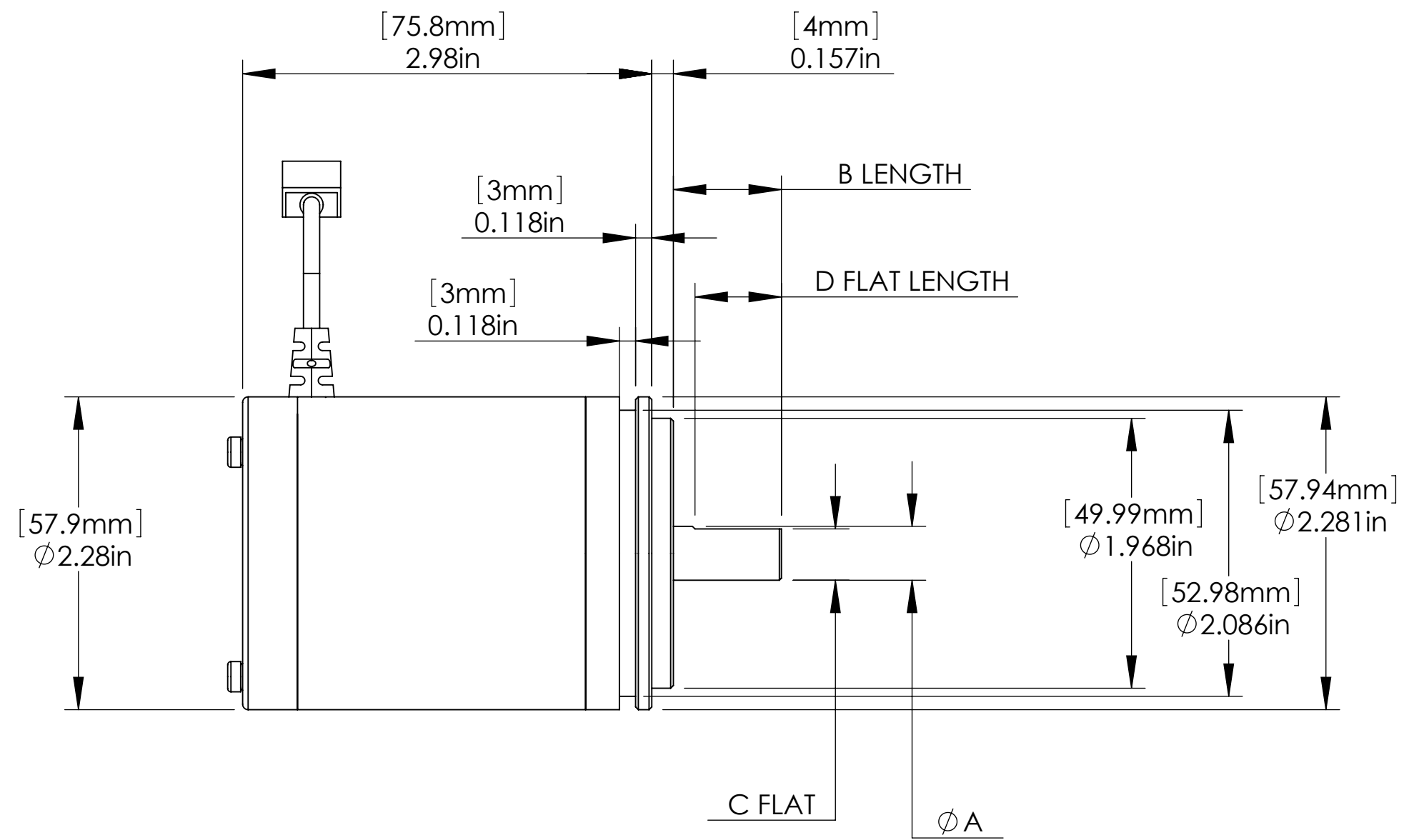

3 X M4x0.7 - 6H ∇ 0.315in [8mm]

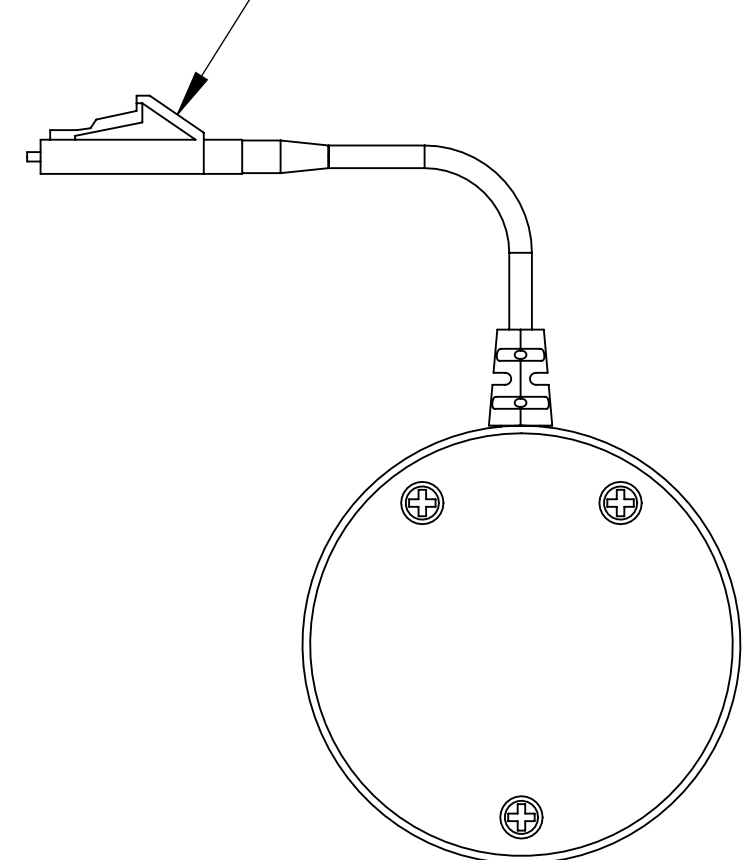
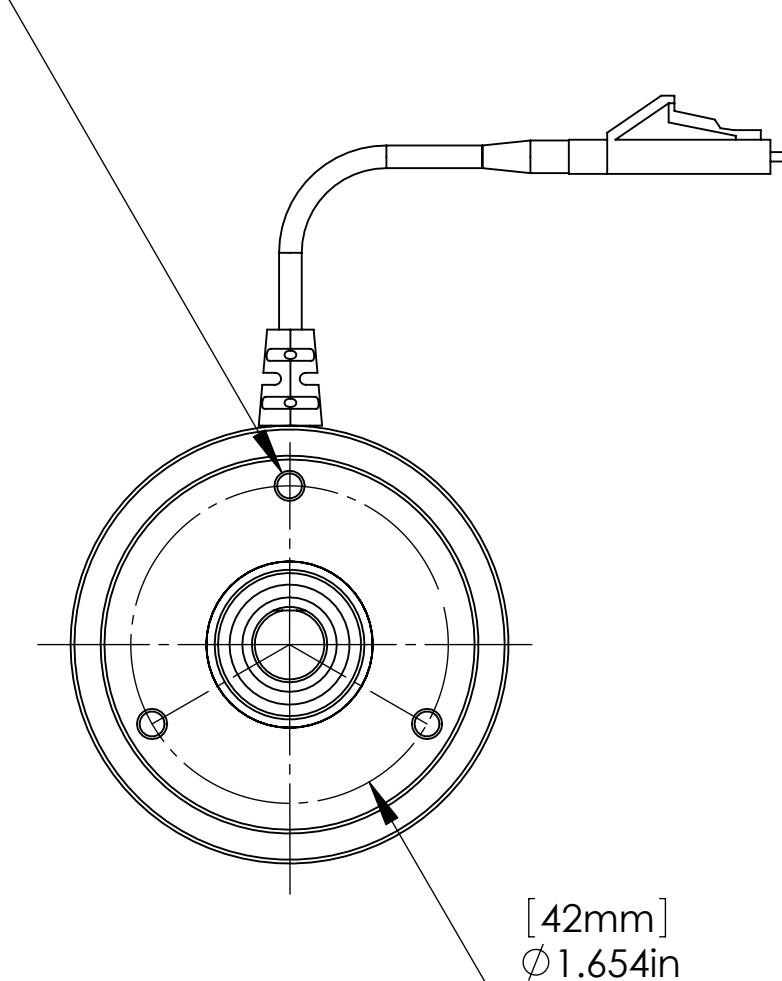

MR338 - Y 10 C 10

- SHAFT SEAL
Y = SEAL (IP66)
N = SHIELD ONLY
- SHAFT DIAMETER
10 = 10mm
- OPTICAL CONNECTOR
C = DUPLEX LC
- OPTICAL PIGTAIL LENGTH
05 = 5m (16.4FT)
10 = 10m (32.8FT)
- TEMPERATURE RANGE
(BLANK) = STANDARD
(-40°C TO +80°C)

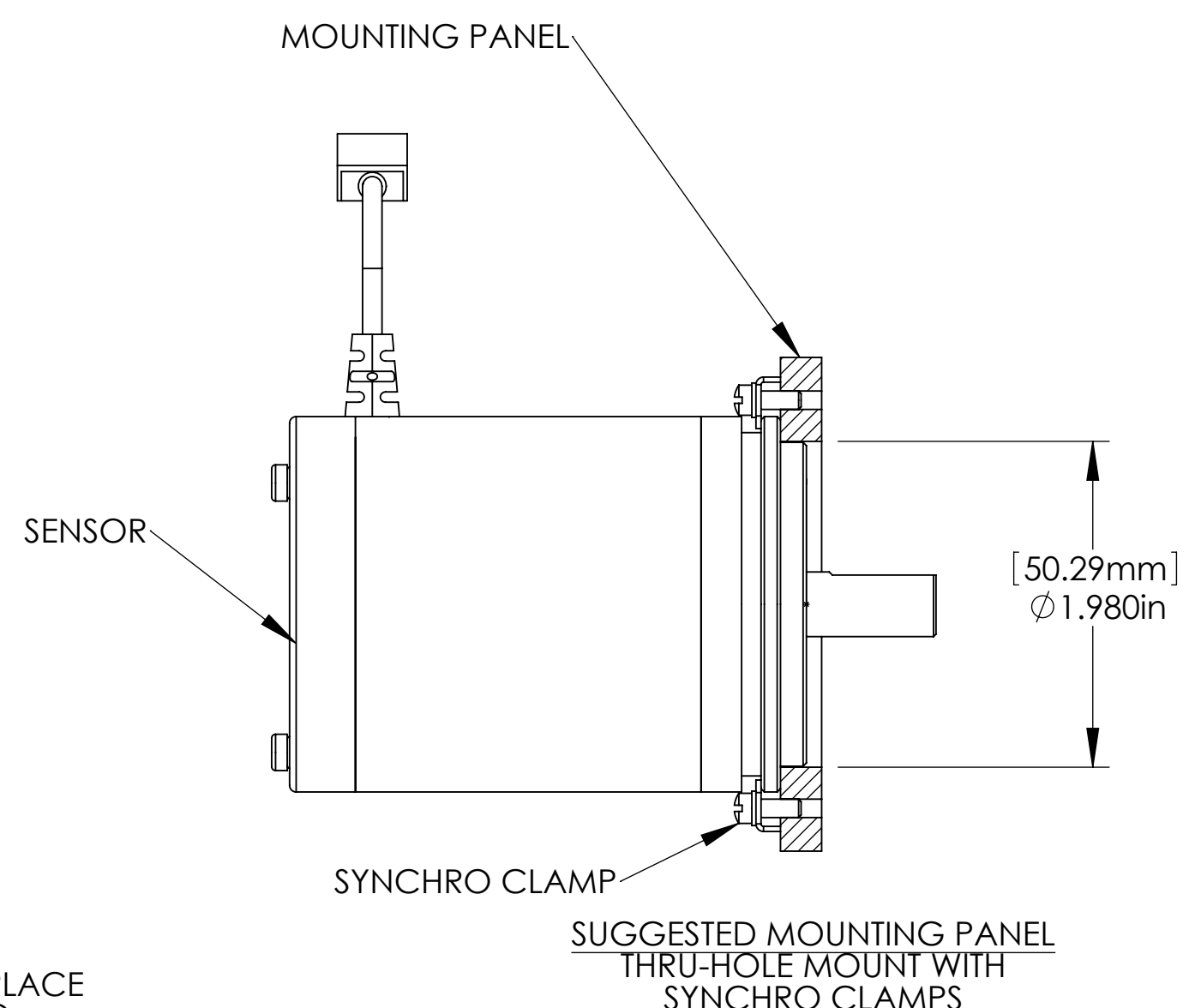

SUGGESTED MOUNTING PANEL
THRU-HOLE MOUNT WITH
SYNCHRO CLAMPS

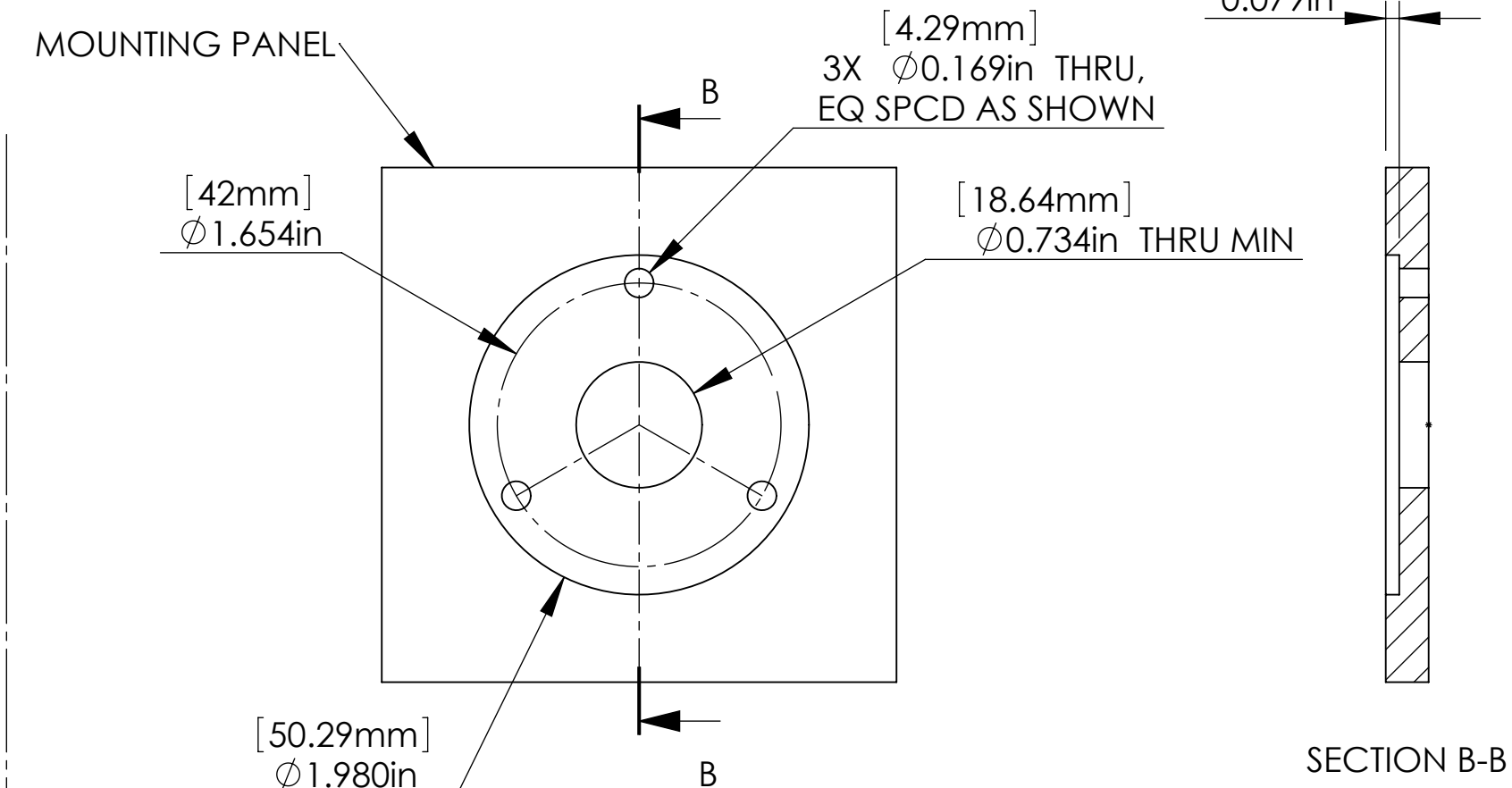

SUGGESTED MOUNTING PANEL
COUNTER-BORED PANEL
WITH MOUNTING SCREWS

3. WARNING: KEEP CONNECTOR COVERS IN PLACE DURING STORAGE, TO PROTECT FIBER OPTIC INTERFACES.
 2. WARNING: DO NOT DROP UNIT. DROPPING OR OTHER SEVERE SHOCK IMPACTS MAY DAMAGE UNIT.
 1. ALWAYS USE FLEXIBLE COUPLING WHEN MOUNTING SHAFT TO EXTERNAL EQUIPMENT.
- NOTES: UNLESS OTHERWISE SPECIFIED

SHAFT CODE SIZE	Ø A	B LENGTH	C FLAT	D FLAT LENGTH
10	.3932 ± .0003 [9.987 ± .0076]	.787 ± .010 [20]	.374 [9.50]	.630 [16]

UNLESS OTHERWISE SPECIFIED: DIMENSIONS ARE IN INCHES TOLERANCES: ANGULAR: ± .5° TWO PLACE DECIMAL ± .02 THREE PLACE DECIMAL ± .005 FOUR PLACE DECIMAL ± .0010	DRAWN	R BOYER	2-5-13	MICRONOR INC. NEWBURY PARK, CA (805) 499-0114
	CHECKED			
	ENG APPR.			
	MFG APPR.			
INTERPRET GEOMETRIC TOLERANCING PER:	Q.A.			TITLE: SENSOR, MRI COMPAT. DUPLEX LC PIGTAIL
MATERIAL	COMMENTS:			SIZE DWG. NO. REV C MR338-X10CXX A
FINISH				SCALE: 1:1 WEIGHT: SHEET 1 OF 1
DO NOT SCALE DRAWING				

PROPRIETARY AND CONFIDENTIAL
THE INFORMATION CONTAINED IN THIS DRAWING IS THE SOLE PROPERTY OF MICRONOR CORPORATION. ANY REPRODUCTION IN PART OR AS A WHOLE WITHOUT THE WRITTEN PERMISSION OF MICRONOR CORPORATION IS PROHIBITED.