

ESH140 SERIE



for machining, control panels, cranes

- ➡ Different output signals
- ➡ Helix cable
- ➡ with mounting magnet
- ➡ Protection class IP 60

Product description

The Series ESH140 is perfect for control up to 6 axis machines. It is easy to switch between the different axes and feed with stable rotary switches. On request we also could seal them. The hand wheel give per turn 100 pulses to the controller.

Application

This series is placed in front of all machines, cranes and different apparatus which has to control several axes.

Technical information

Pulses	100
Channels	2 + 4
Power supply	5V DC
Output driver	Pull up / Line driver
Selector switches for axes	1...6
Switches for resolution	1...3
Emergency stop	Single or Doubled
Helix cable	PUR
Protection	IP 60
Magnetic clamp	Option

ESH140 SERIE



Dimension in mm

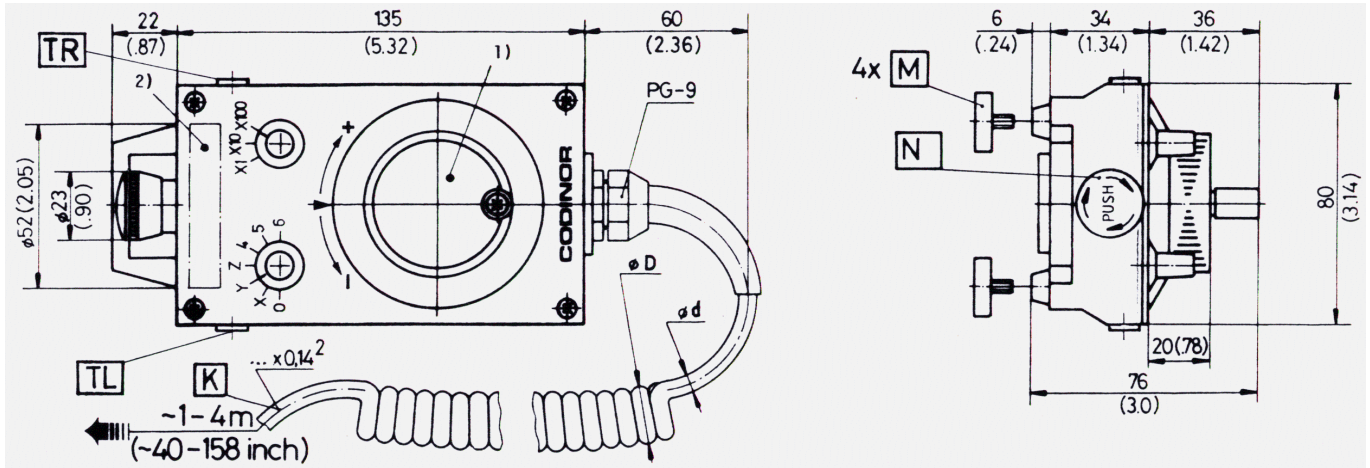

Output Signal (Handwheel)

Output channel
M70
cp = Click point

M74
p = Periode

/ Output driver
Pull up (2 KΩ intern)

Line driver (RS 422)

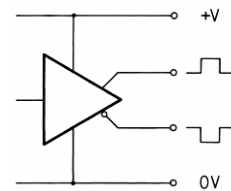
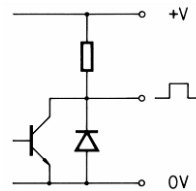
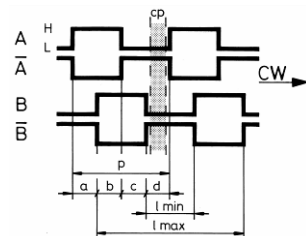
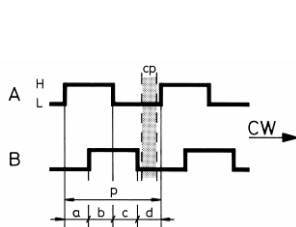

Electrical schema

could change with configuration

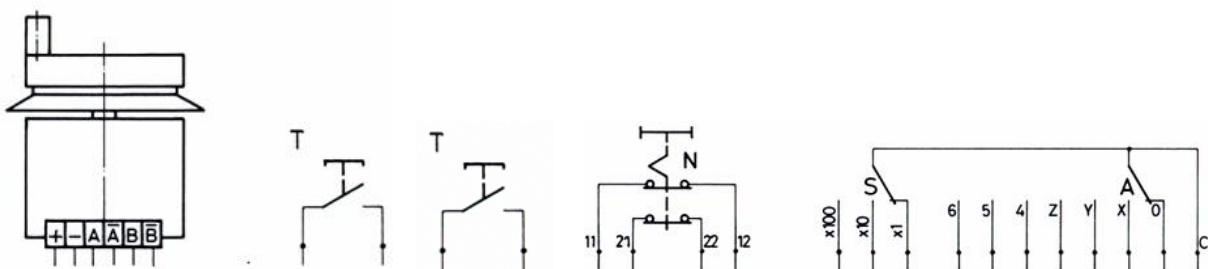

ESH140 SERIE



Order Code

		94	X	X	X	X	X	X	X
OUTPUT DRIVER									
6	A , B	Pull-up 5V DC ±5% / ESM70							
7	A , B , A' , B'	Line driver 5V DC ±5% / ESM74							
SWITCH FOR AXES									
0	0, X, Y, Z								
1	0, X, Y, Z, 4								
2	0, X, Y, Z, 4, 5								
3	0, X, Y, Z, 4, 5, 6								
FOR RESOLUTION S									
0	x1								
1	x1, x10								
2	x1, x10, x100								
ENABLE SWITCH T									
0	none								
1	Right side: (1 x ON) 0,15A 125V AC / 0,4A 30V DC								
2	Left side: (1 x ON) 0,15A 125V AC / 0,4A 30V DC								
2	Right and left side: (1 x ON) 0,15A 125V AC / 0,4A 30V DC								
EMERGENCY STOP N									
0	none								
1	1 x OFF 1,5A 250V AC (61)								
2	2 x OFF 1,5A 250V AC (62)								
HELIX CABLE									
0	12 x 0.14mm ² (AWG26)								
1	18 x 0.14mm ² (AWG26)								
2	25 x 0.14mm ² (AWG26)								
MAGNETIC CLAMP									
0	none								
1	Ø 50mm								



Questions ?

Phone: +41 (0)44 843 40 20 or Mail: sales@micronor.ch