

Resolverunit with initial conversion
Resolvereinheit mit Eingangübersetzung

Serie FR90



- Two Resolver, both Typ size 11 or size 15
- Or Resolver MICRONOR Typ 3616
- Input gear reduction 1 : 1 ... 10 : 1 (slowly)
- Input speed increasor 1 : 1 ... 1 : 6 (fast)
- Compact housing with plug connection
- Synchroflange execution
- Protection class IP63
- Also additionally with Tacho available

Technical data

Working temperature	-20 °C +85 °C
Revolution speed	<6000 min ⁻¹ (rpm)
Weight	≈750g
Storage temperature	-30 °C +90 °C
Humidity	85% RH
Shock resistance	294 m/s (each 3 times)
Protection class	IP50 on request IP63
Vibration resistance	10 ... 55Hz / 1.5mm 1.2h

Outline drawing

Ø d = 9-h8 (DIA .3543) s = 8.5 (.3346) / F = → 40N ↓ 80N / MS = Mounting flange / H = 82mm / E = M3
 Ø d = 9.52-8h (DIA .3748) s = 9.0 (.3543)

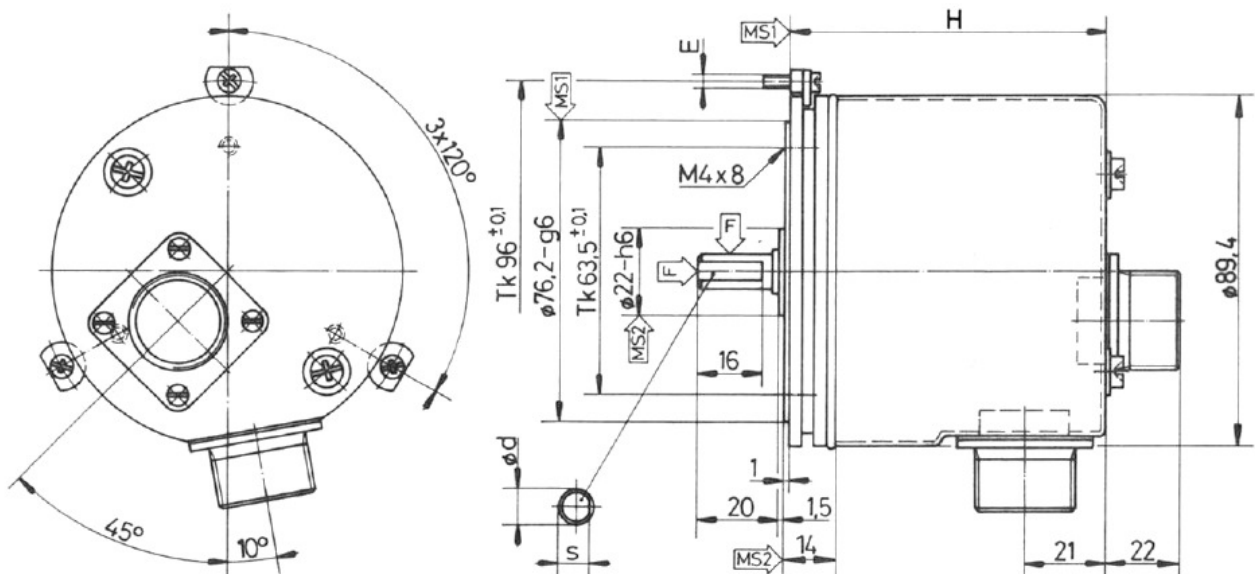

Serie FR90

Electrical connection

Standard wiring

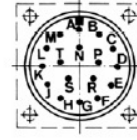
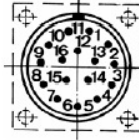

Flange socket

SFP 16 (16 PIN) DIN

MS 3102 A 20-29 P (17 PIN) MIL

Wire colour	Resolver	R1	Pin Nr.	Pin Nr.
White /Red	R1	Rotor	1	A
White / Black	R2		2	B
Red	S1	Stator	3	C
Black	S3		4	D
Yellow	S2		5	E
Blue	S4		6	F

Wire colour	Resolver	R1	Pin Nr.	Pin Nr.
White /Red	R1	Rotor	7	G
White / Black	R2		8	H
Red	S1	Stator	9	Jl
Black	S3		10	K
Yellow	S2		11	L
Blue	S4		12	M

Unused output are to isolate before starting

Accessories

Attachment strap 3 x BMF (M3x12mm)

Option

Mating plug straight line (female)	SGS 16.PG9	(16 pin) DIN
Mating plug straight line (female)	MS 3106 A 20-29 S	(17 pin) MIL
Mating plug 90° (female)	MS 3108 B 20-29 S	(17 pin) MIL

Order key

FR90 1 1 1

Dimension: Ø 36,83 mm

Bore:

- 1 = Ø 10-H7 / DIA 393
- 2 = Ø 6-H7 / DIA 236

Resolver:

- 1 = one Resolver RE3616 gear with float accuracy ± 60 Min.
- 2 = two Resolver RE3616 gear with float accuracy ± 60 Min.
- 3 = one Resolver REH2840 gear free from float accuracy ± 7 Min.
- 4 = two Resolver REH2840 gear free from float accuracy ± 7 Min.

Male receptacle:

- 1 = SFP16 (16 Pin) DIN
- 2 = MS3102 A 20-29P (17 Pin) MIL

Technische Änderungen vorbehalten / Subject to change without prior notice