

# Position Transducers

MICRON/ EUCRON/BAUMER/GE REPLACEMENTS

**MICRONOR**  
automation components

## Products

Since 1968, Micronor has been manufacturing precision Position Feedback and Control Transducers for OEMs and End-Users throughout many industries; including CNC machine tool, robotics, heavy industry, paper converting and military/aerospace. These products are based on Micronor's MR200 series of modular rotary cam-based components and design concepts.

There are countless applications for Feedback Transducers. In effect, any application of linear or rotary motion through the use of a motor and servo controller can realize improved accuracy and performance through feedback. Feedback units can be engineered to integrate any one or combination of various feedback technologies, including:

- Encoders with digital output signals
- Resolvers with sine and cosine analog signals
- Potentiometers
- Tachometers
- Programmable limit switches
- Torque motor



Position Feedback Transducers Of All Shapes, Sizes and Function



## Micron Replacements

Micronor specializes in engineering and manufacturing replacement Feedback Units (FBUs) for maintaining or repairing machinery no longer supported by their original parts manufacturers. We can supply replacements for obsolete FBUs previously manufactured by Micron, Eucron, Thomson Micron, Baumer, GE, Kearfott, Singer, Crouzet and others.

We have an extensive library of Micron/Eucron documentation as well as exceptional experience in reverse engineering many special purpose Micron configurations. Generically, the prefixes (first two digits) of Thomson Micron/Eucron part numbers identify the basic transducer or component type:

- 36 series Geared Resolvers (single, double and triple)
- 39 series Handwheels (encoder and resolver based)
- 45 series Rotary Limit Switches
- 50 series Resolver/Limit Switch and Encoder/Limit Switches
- 73 series replacement resolver components

We provide replacement units based on a wide range of Micron configurations, including: Ø2.5" flange mount, Ø3.5" flange mount, Ø 4" face mount, Ø4.25" Indramat and Ø7" EX.



# Micron $\varnothing 2.5$ " Synchro Mount Reference Drawing

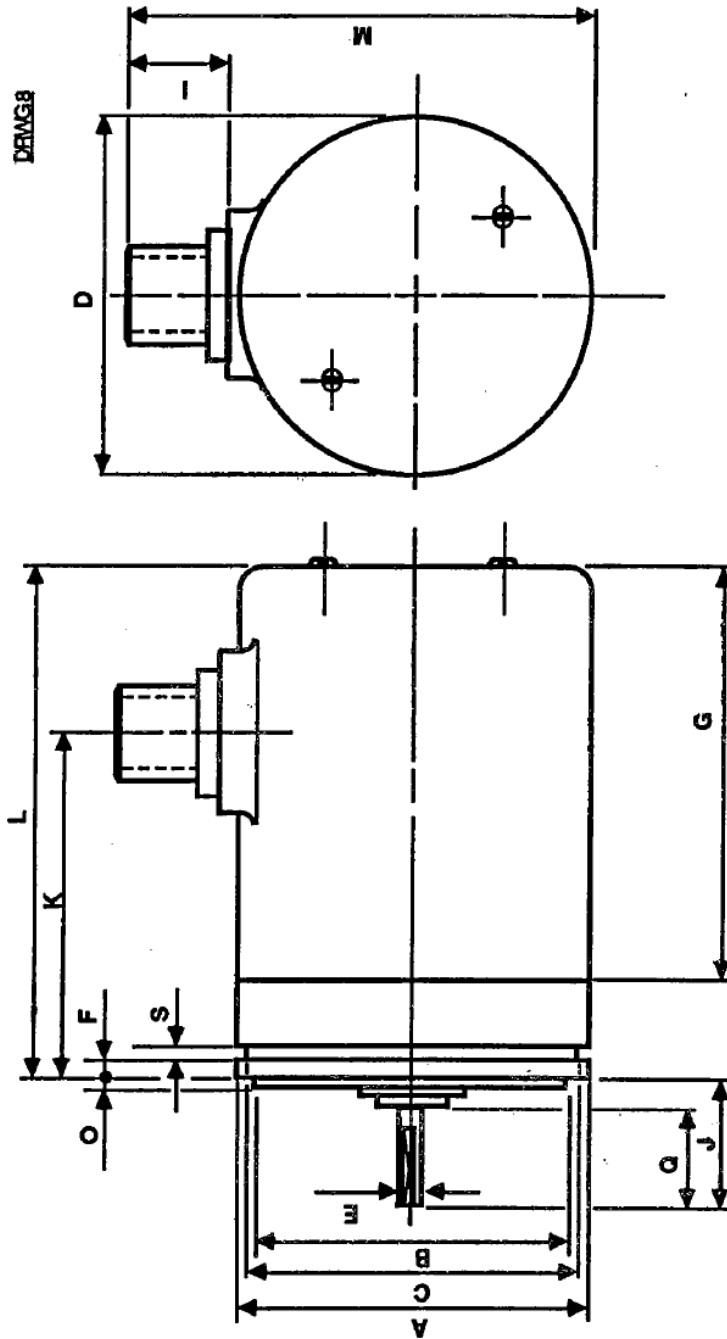

All dimensions are in inches

DIM A = 2.620	B = 2.500	C = 2.500	D = 2.500	E = 0.500	F = 0.120	G = 3.000
DIM H = 0.000	I = 0.880	J = 1.760	K = 2.656	L = 3.676	M = 3.520	N = 0.000
DIM O = 0.130	P = 0.000	Q = 1.539	R = 0.000	S = 0.000	T = 0.000	U = 0.000

# Micron Ø2.5" Flange Mount Reference Drawing

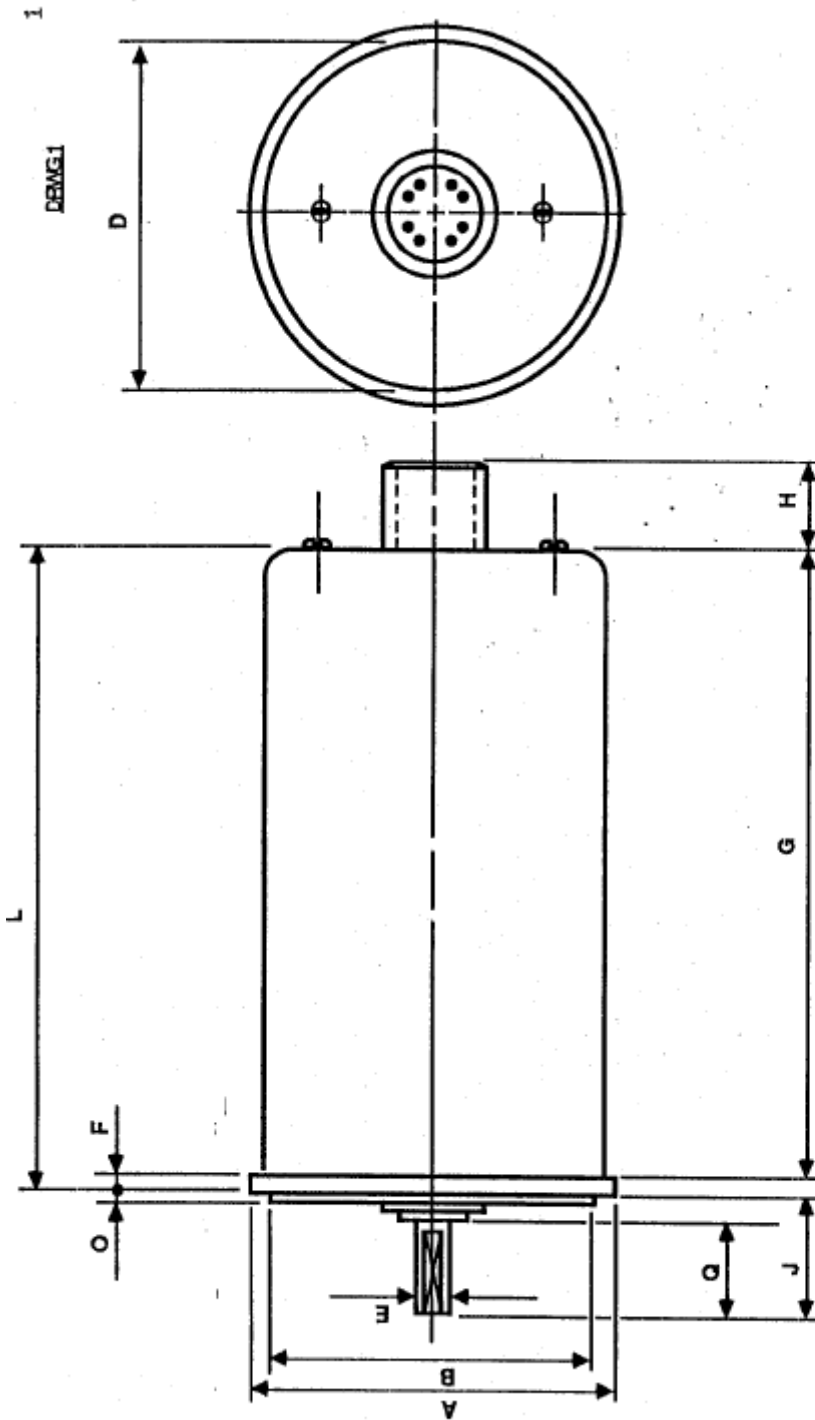

DIM A = 2.620	B = 2.500	C = 0.000	D = 2.500	E = 0.250	F = 0.120	G = 4.320
DIM H = 0.600	I = 0.000	J = 1.014	K = 0.000	L = 4.440	M = 0.000	N = 0.000
DIM O = 0.130	P = 0.000	Q = 0.813	R = 0.000	S = 0.000	T = 0.000	U = 0.000

All dimensions are in inches

# Micron $\varnothing 3.5$ " Synchro Mount Reference Drawing

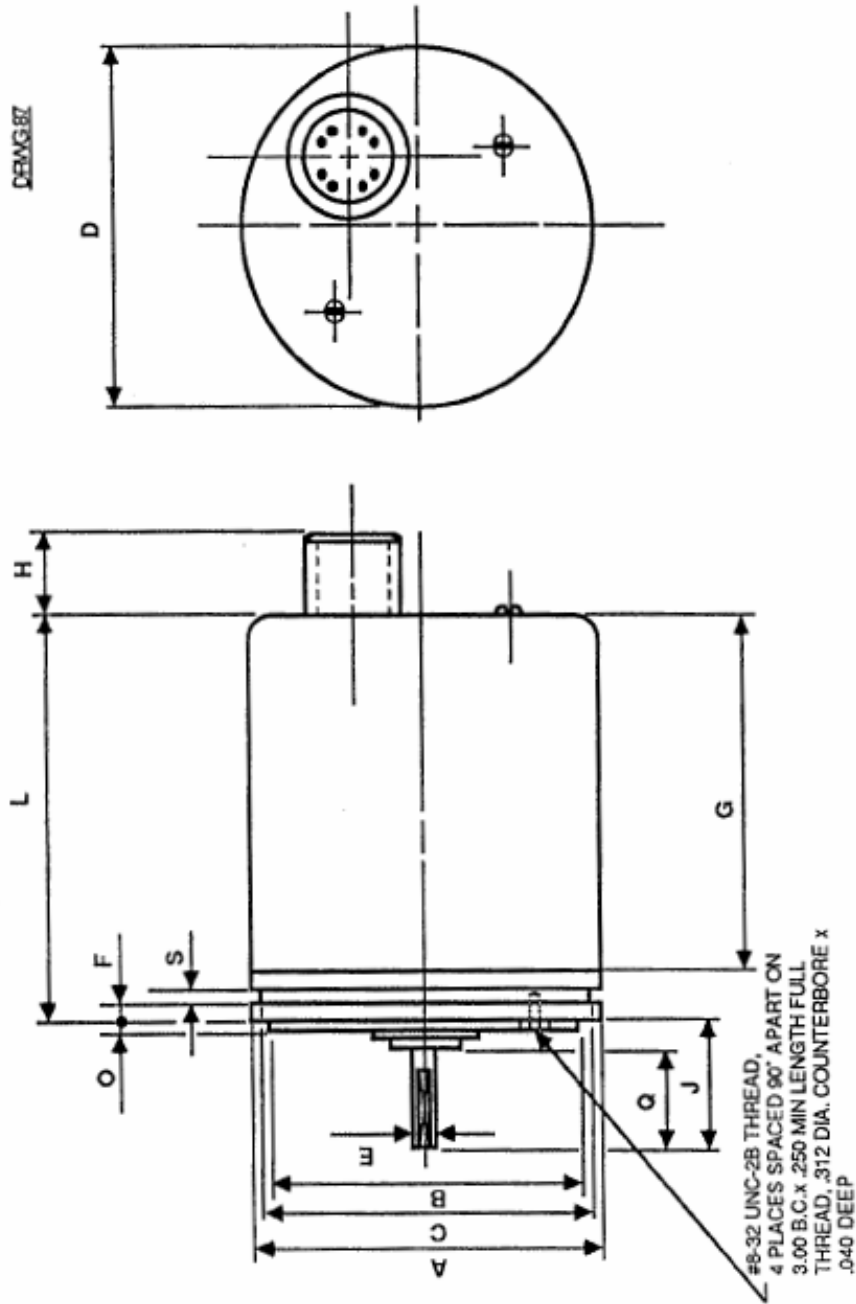

DIM A= 3.500	B= 3.000	C= 3.250	D= 3.500	E= 0.375	F= 0.125	G= 3.270
DIM H= 0.600	I= 0.000	J= 0.826	K= 0.000	L= 3.730	M= 0.000	N= 0.000
DIM O= 0.040	P= 0.000	Q= 0.695	R= 0.000	S= 0.120	T= 0.000	U= 0.000

All dimensions are in inches

# Micron $\varnothing 4$ " Face Mount Reference Drawing

DRIVE 106

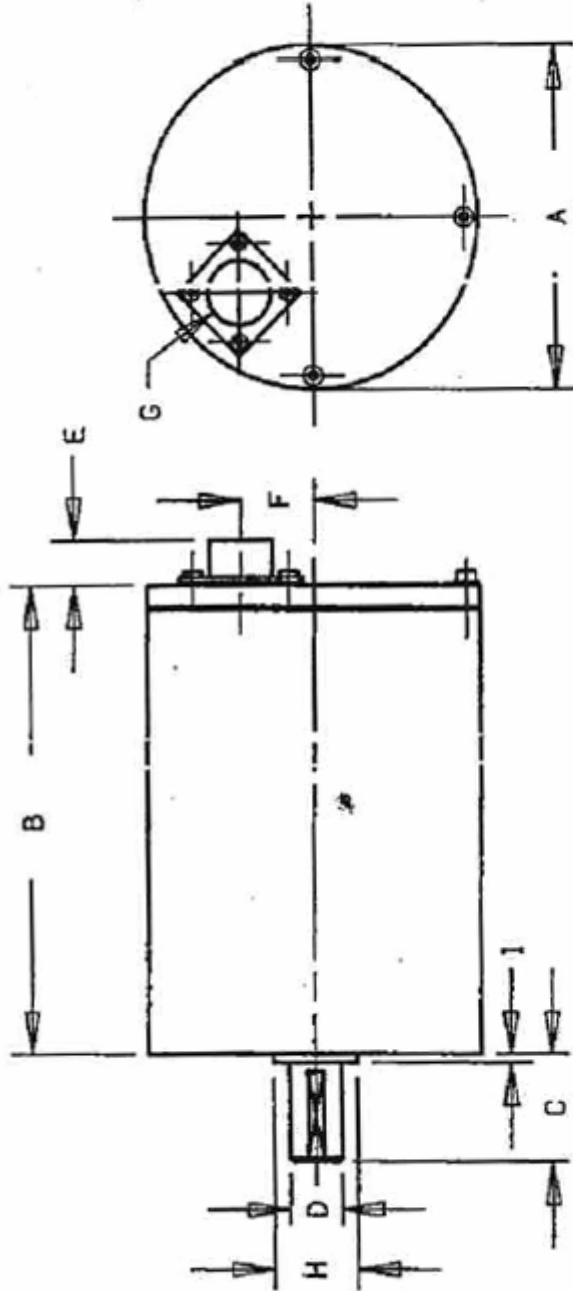

DIM A=	4.000	B=	5.401	C=	1.250	D=	0.625	E=	0.433	F=	0.875	G=	0.750
DIM H=	0.000	I=	0.000	J=	0.000	K=	0.000	L=	0.000	M=	0.000	N=	0.000
DIM O=	0.000	P=	0.000	Q=	0.000	R=	0.000	S=	0.000	T=	0.000	U=	0.000

All dimensions are in inches

# Micron Ø3" "Tapered" Indramat Servo Mount Reference Drawing

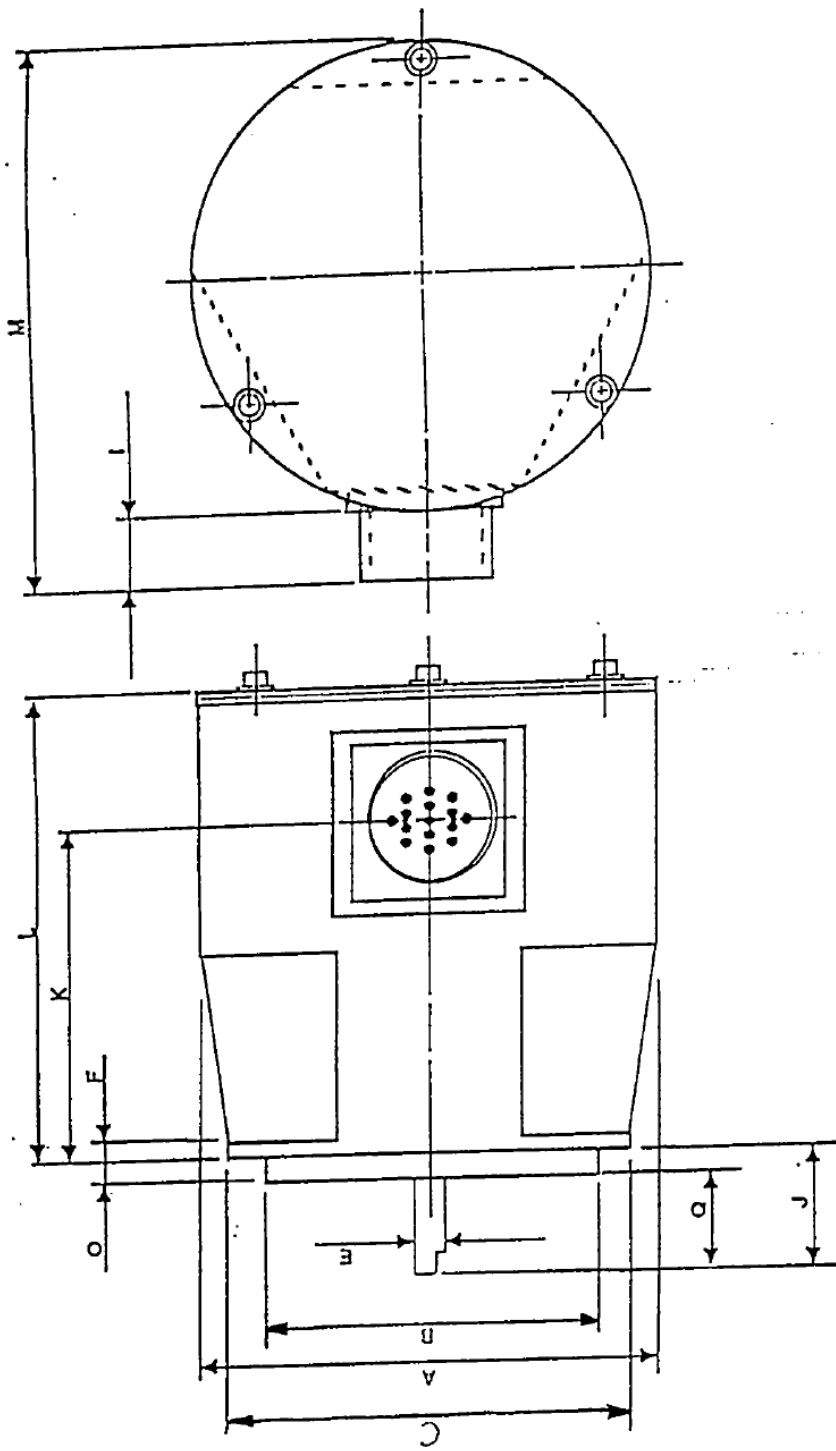

DIM A = 3.250	B = 1.969	C = 0.000	D = 0.000	E = 0.236	F = 0.125	G = 0.000
DIM H = 0.000	I = 0.000	J = 0.590	K = 2.170	L = 3.320	M = 3.910	N = 0.000
DIM O = 0.060	P = 0.000	Q = 1.120	R = 0.000	S = 0.000	T = 0.000	U = 0.000

All dimensions are in inches

# Micron Ø4.25" Indramat Servo Mount Reference Drawing

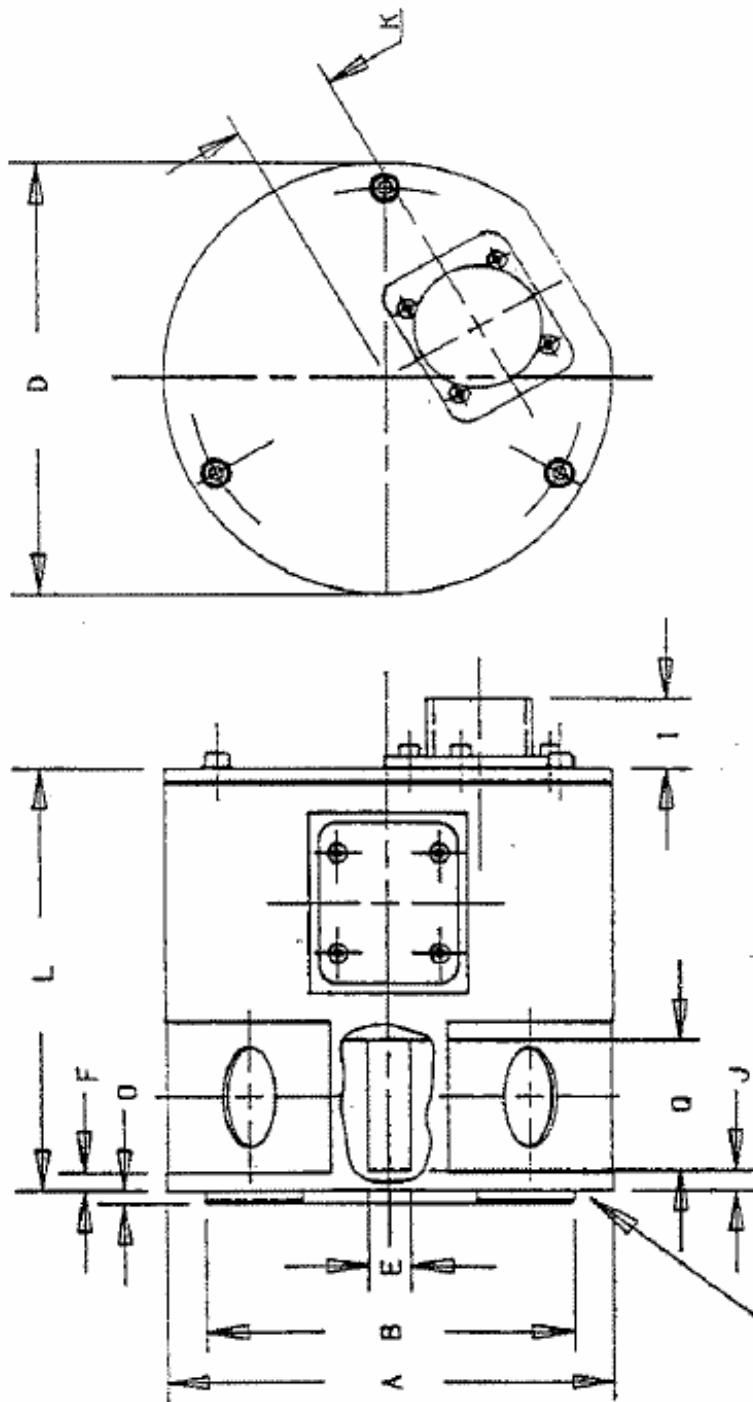

.160 DIA. HOLE, 3 PLACES EQUALLY  
SPACED ON A 3.75 DIA. BOLT CIRCLE

DIM A = 4.250	D = 4.250	E = 0.394	F = 0.180	G = 0.000
DIM H = 0.000	K = 1.000	L = 4.155	M = 0.000	N = 0.000
DIM D = 0.125	R = 0.000	S = 0.000	T = 0.000	U = 0.000
B = 3.498	C = 0.000			
I = 0.680	J = 0.580			
P = 0.000	Q = 0.770			

All dimensions are in inches

# Micron Ø7" Heavy Duty EX Flange Mount Reference Drawing

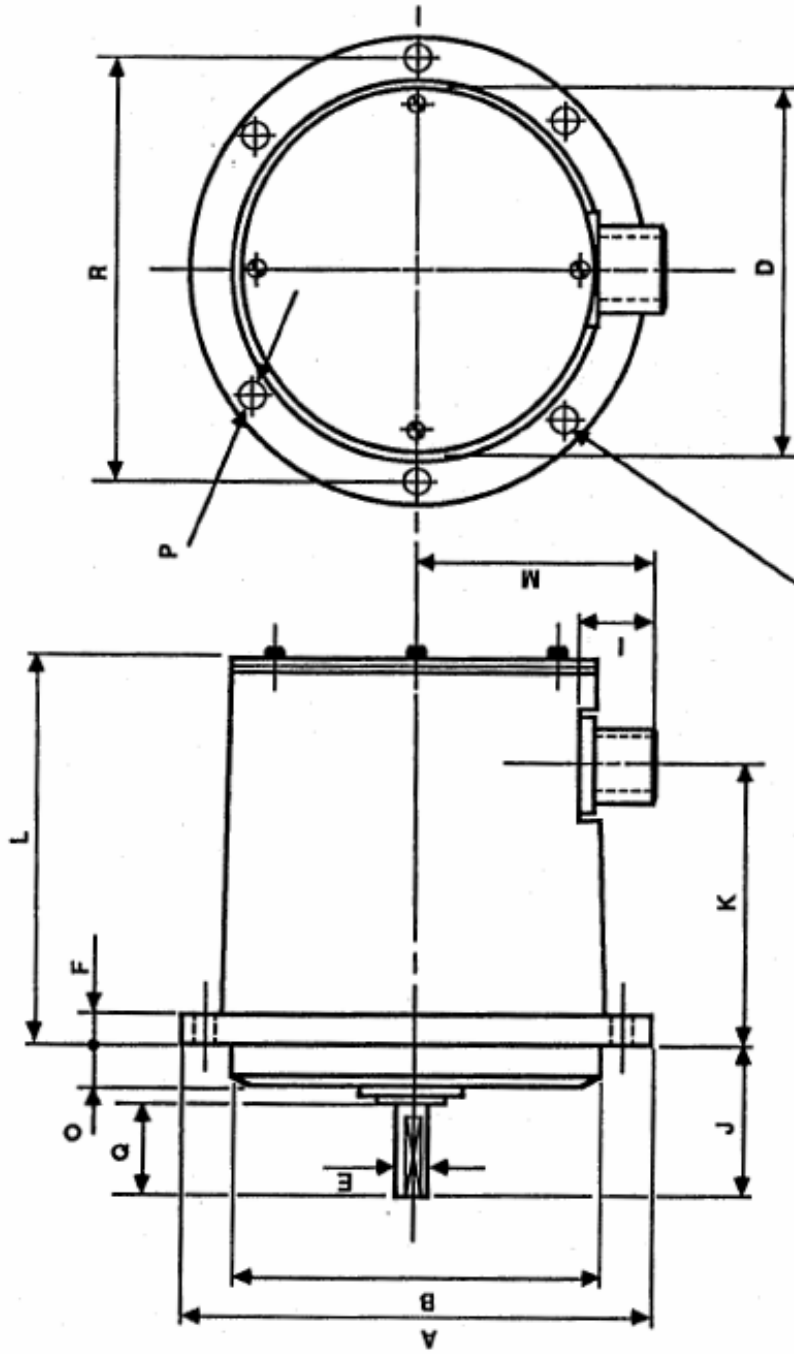

.281 DIA. DRILL THRU 6 PLACES  
SPACED EQUALLY ON 6.312 DIA. B.C.

DIM A = 6.940	B = 5.500	C = 0.000	D = 5.620	E = 0.500	F = 0.250	G = 0.000
DIM H = 0.000	I = 0.800	J = 1.630	K = 3.000	L = 4.640	M = 3.500	N = 6.000
DIM Q = 0.380	P = 0.281	Q = 1.223	R = 6.312	S = 0.000	T = 0.000	U = 0.000

All dimensions are in inches



## How To Help Us Identify Your Micron Position Transducer Configuration:

Please appreciate that every Micron feedback transducer ever produced is a unique combination of many, many variables – housing/mounting type, gear ratios, type of resolver, number of limit switches, connector types, connector position, etc... There was no one standard but there were some elements that were more common than others. Statistically, about 70% of the replacements we manufacture tend to share these common attributes:

- Ø3.5" flange mount housing with 3/8" Ø shaft with dual flats
- Use Harowe 11BRW-300-F-95A resolvers (Micron 73-202-730)
- Mil-Style MS3102A series connector receptacles – either axial or flange mount

### Steps to follow:

1. **NOTE MICRON PART NUMBER.** A Baumer/Eucron/Micron feedback unit has an 11-digit part number. This can be found on both the side and rear labels – if the printing is still visible. The inside connector mounting plate may also have the unit's part number stamped or printed onto it.
2. **IF POSSIBLE, SHIP THE NON-FUNCTIONAL UNIT TO MICRONOR INC.** If your unit is non-functional, the quickest way for us to identify all configuration parameters is for you to simply drop the unit in a box and ship it overnight to us – from anywhere in the world. In just a few days, we have all of the answers instead and going back in forth with emails and faxes. Although a unit may be mechanically worn, sometimes we can replace the internal resolver and get you up and running until a new replacement can be manufactured (typically 8-16 weeks depending on the complexity of the configuration).
3. **TAKE PHOTOS AND NOTE ALL OUTSIDE LABEL TEXT/INTERNAL COMPONENT MARKINGS.** If you can't send us a unit, then take a few digital photos of the outside and inside of the unit and email them to [sales@micronor.com](mailto:sales@micronor.com) . You only have to remove a few rear screws and pull back the rear cover – enough to expose as much of the inner assembly as practical. Note any legible text on the outside labels of the unit plus all markings on the internal resolvers or encoders.
4. **NOTE DIMENSIONS.** What are the outer dimensions of the housing and main shaft. Does the shaft have flat(s) or keyway? The following Micron reference drawings show most common dimensions for these packages. Your unit may vary in terms of shaft size, mounting features, housing length, connector location, etc.
5. **HOW MANY SWITCH CHANNELS?** If the unit incorporates limit switches, how many channels are there?

## How To Program Micronor Universal Cam Switches When Replacing Micron Type A, B or I Switches

Micronor Limit Switches use a "universal" double cam design. Thus, the Micronor double cam limit switch replaces 3 types of Thomson Micron limit switches (A,B and I). To connect to the proper switch contacts and set the cams properly, you will need to know the type of switch used on each channel of the original Micron unit.

**Type A** - Forced actuation in in CW rotation of Input, reset on CCW rotation past set point

**Type B** - Forced actuation in in CCW rotation of Input, reset on CW rotation past set point

**Type I** - Impulse at set point

### How To Program Micronor Cams

For Type A operation where On (closed contacts) period  $<180^\circ$ , use COM and NO switch contacts and program "valley" of switch "On" at Set Point and "Off" at about  $355^\circ$ . If On period  $>180^\circ$ , then use COM and NC contacts and program "peak" of switch "On" at Set Point and "Off at  $355^\circ$ .

For Type B operation where On (closed contacts) period  $<180^\circ$ , use COM and NO switch contacts and program "valley" of switch "On" at  $\sim 355^\circ$  and "Off" at Set Point. If On period  $>180^\circ$ , then use COM and NC contacts and program "peak" of switch "On" at Set Point and "Off at  $355^\circ$ .

For Type I operation (assume impulse to be about  $6^\circ$  wide, use COM and NO switch contacts and program "valley" of switch "On" at Set Point and "Off" at SetPoint+ $6^\circ$ .

### THOMSON MICRON Switch Types

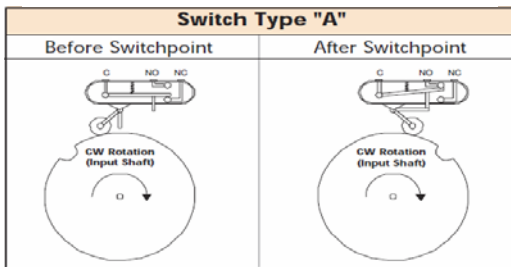

### Switch Activation Profile

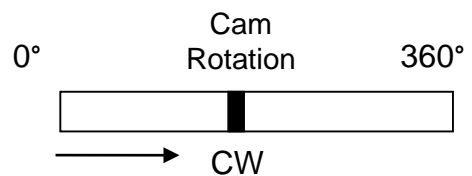
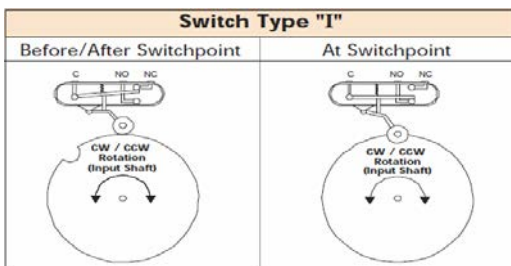
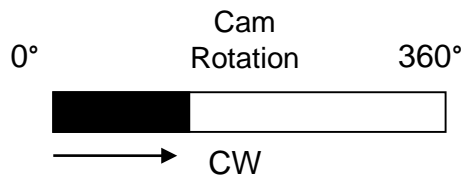
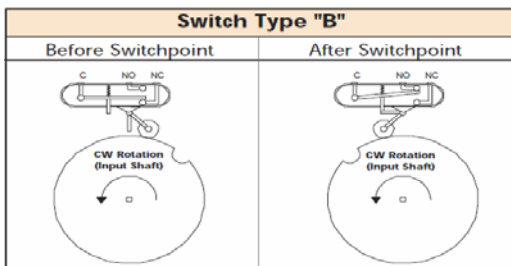
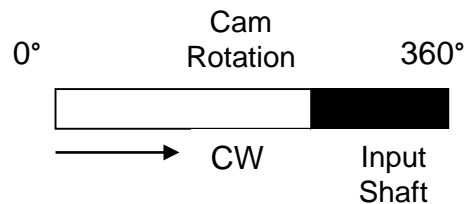

Denotes Closed Contact

# Replacement Paper Converting Transducers

Feedback Units used on machinery by Paper Converting Machine Company:

- Micron 36-509-023-1958 – replaced by Micronor 9600.00.010
- Micron 36-509-023-2003 – replaced by Micronor 9600.00.011
- Micron 36-513-113-5642 – replaced by Micronor 9600.00.012
- Micron 36-509-391-1922 – replaced by Micronor 9600.00.021
  
- Micron 36-515-037-7662 – replaced by Micronor 9600.00.018
- Micron 36-509-391-1922 – replaced by Micronor 9600.00.021
- Micron 36-308-705-1742 - replaced by Micronor 9600.00.065
  
- Micron 39-115-209-7965 – replaced by Micronor 9000.00.016
- Micron 39-410-986-2187 – replaced by Micronor 9100.00.013
- Micron 39-409-755-1998 – replaced by Micronor 9100.00.113



# Replacement Resolvers, Tachometers and Torque Motors

- Micron 73-202-730 or Harowe 11BRW-300-F-95A - replaced by Micronor R11WF103
- Micron 73-202-831-2 or ServoTek SA740B-1 - replaced by Micronor SA740B1
- Micron 73-204-479 or Harowe 11BRW-300-M95B - replaced by Micronor R11WM107
- Micron 73-204-671 or Harowe 11BRCX-300-J-95C - replaced by Micronor R11XJ107
- Micron 73-204-860 or Harowe 11BRCX-300-C95-6 - replaced by Micronor R11XC107
- Micron 73-205-144 or Harowe 11BRCX-300-G95-6 - replaced by Micronor R11XG107
- Micron 73-206-080 or Harowe 11BRCX-300-J95- - replaced by Micronor R11XJ107
- Micron 73-206-879 or Clifton 11-BHW-50F/F533 - replaced by Micronor R11BHW50FF533
- Micron 73-208-808 or Clifton 11-BHW-48SV/F639 - replaced by Micronor R11BHW48SVF639
- Micron 73-203-209-X or ARC Systems or Transcoil torque motors - contact Micronor

**R11 Series Resolver**

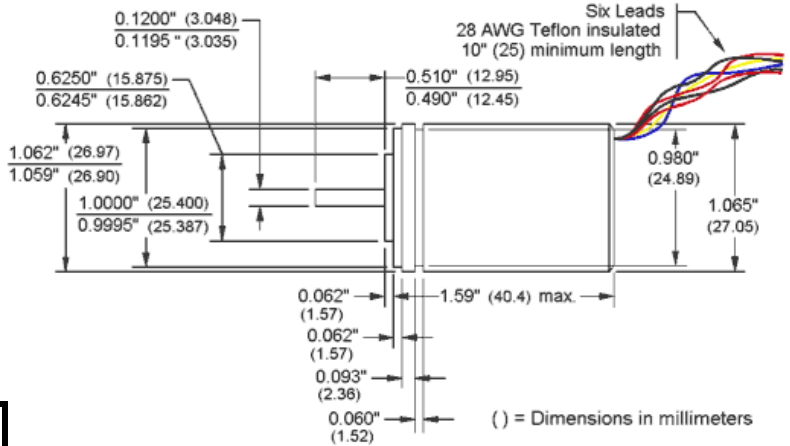

Lead Color	Function
Red/White	Rotor 1
Black/White or Yellow/White	Rotor 2
Red	Stator 1
Yellow	Stator 2
Black	Stator 3
Blue	Stator 4

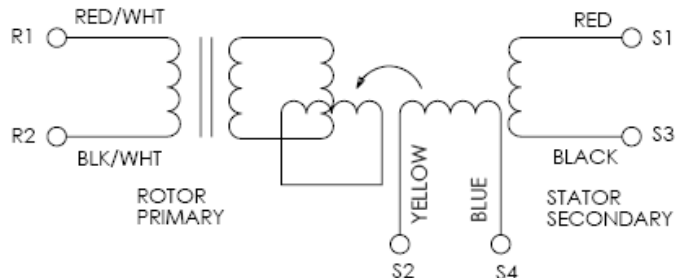

## Some of the other replacements that we have made and are manufactured to order:

- Micron 36-205-488-1888 – replaced by Micronor 8200.01.001
- Micron 36-207-040-1283 - replaced by Micronor 8200.01.010
  
- Micron 36-205-681-1506 - replaced by Micronor 9000.00.035
- Micron 36-300-748-0025 - replaced by Micronor 9800.10.141
- Micron 36-300-748-0663 - replaced by Micronor 9000.00.069
- Micron 36-306-670-1532 - replaced by Micronor 9000.00.041
- Micron 36-315-060-7710 - replaced by Micronor 9000.08.002
- Micron 45-307-526-1830 - replaced by Micronor 9800.10.290
- GE 3N1000FB200Y3/Ingersoll 2101188 – replaced by 9000.12.048
- GE 3N1000FB103E2 - replaced by Micronor 9200.00.607
  
- Micron 36-515-037-7662 - replaced by Micronor 9600.00.018
- Micron 36-509-391-1922 - replaced by Micronor 9600.00.021
  
- Baumer 36-399-200-9188 - replaced by Micronor 9600.00.014
- Kearfott/Micron 36-106-423-1137 – replaced by 8200.00.006
- BVR 275910-001/Ingersoll 2100816 – replaced by 9000.00.045



Contact your local Micronor sales office concerning your Micron replacement needs. Be sure to have the Micron 12-digit part number available.

We can do some minor repairs on original Micron units – including replacing bearings, cleaning gears and replacing internal resolvers.

For all other configurations plus Motor Pots, Cam Timers, Rotary Limit Switches and Handheld Pendants, please contact the local Micronor sales engineer and they will help guide you to the proper product and configuration.

### MICRONOR INC.

900 Calle Plano, Suite K  
Camarillo, CA 93012  
USA

T +1-805-389-6600  
F +1-805-389-6605  
sales@micronor.com  
www.micronor.com

### MICRONOR AG

Pumpwerkstrasse 32  
CH-8105 Regensdorf  
Switzerland

T +41-44-843-4020  
F +41-44-843-4039  
sales@micronor.ch  
www.micronor.com