

| | | | |
|-----------|--------------|------|------------|
| F9J GC BG | | | |
| F9J | 89G7 F DHC B | 85H | 5DDFC J 98 |
| 5 | B9K F9@95G9 | &!%& | F: 6 |

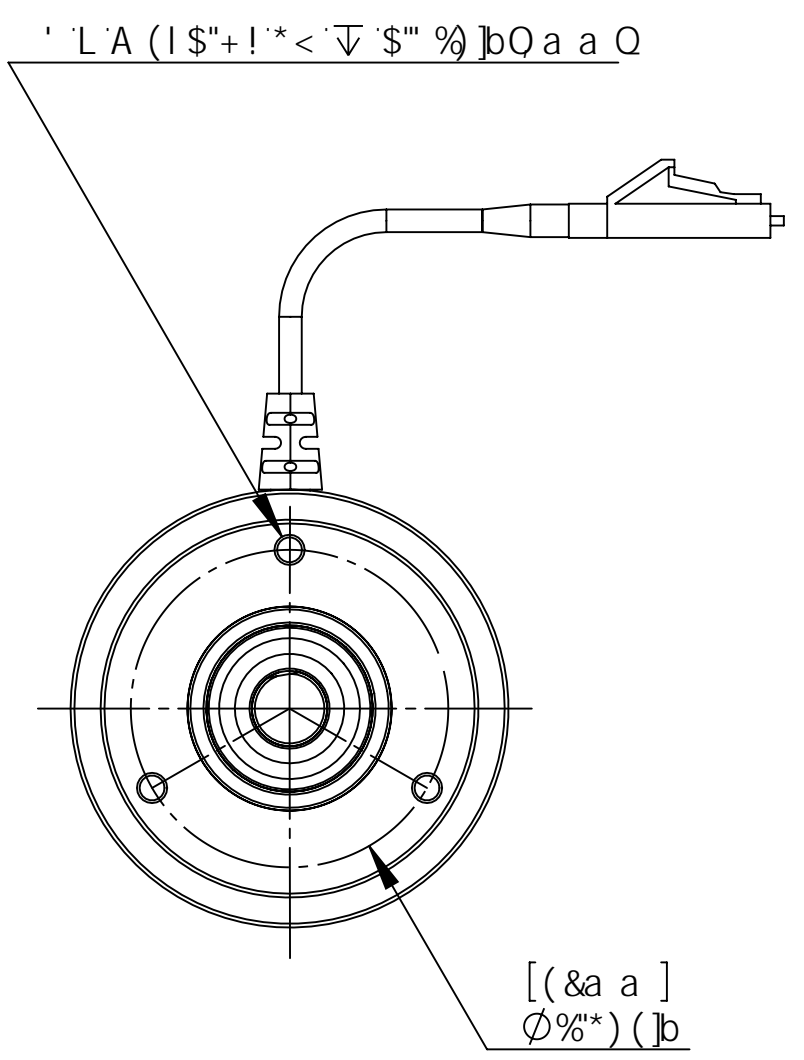

A F ' ' & ! M % \$ 7 ' \$ ' ' .

G<5: HG95@
 "M'1 G95@fH@* *L
 "B'1 G<9@8 C B@M
 G<5: H8 5A 9HF
 "\$* '1 * a a
 "%\$ '1 % \$ a a
 "-) '1 "" +) -B# ") & a a
 C DH7 5@7 C BB97 HC F
 "7 '1 81 D@L @/
 C DH7 5@D= H5 @@B; Hk
 "\$ '1 ' a fl " : H
 "\$) '1) a fl @ " (: H
 "%\$ '1 % \$ a fl & " : H
 H9A D9F5H F9F5B; 9
 "f6@5B?L'1 G5B85F8
 "fl (\$ 7 HC Z , \$ 7 L

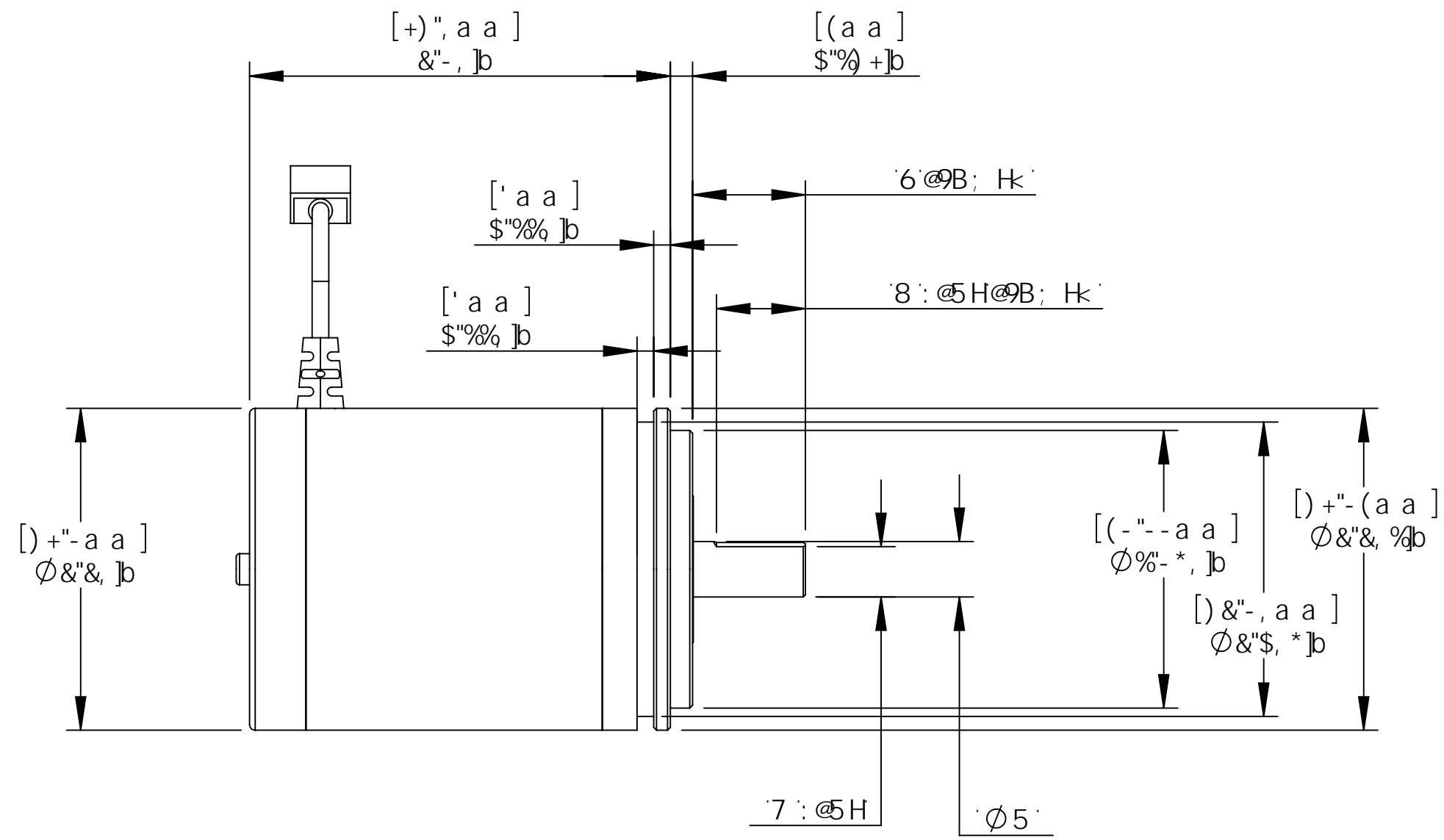
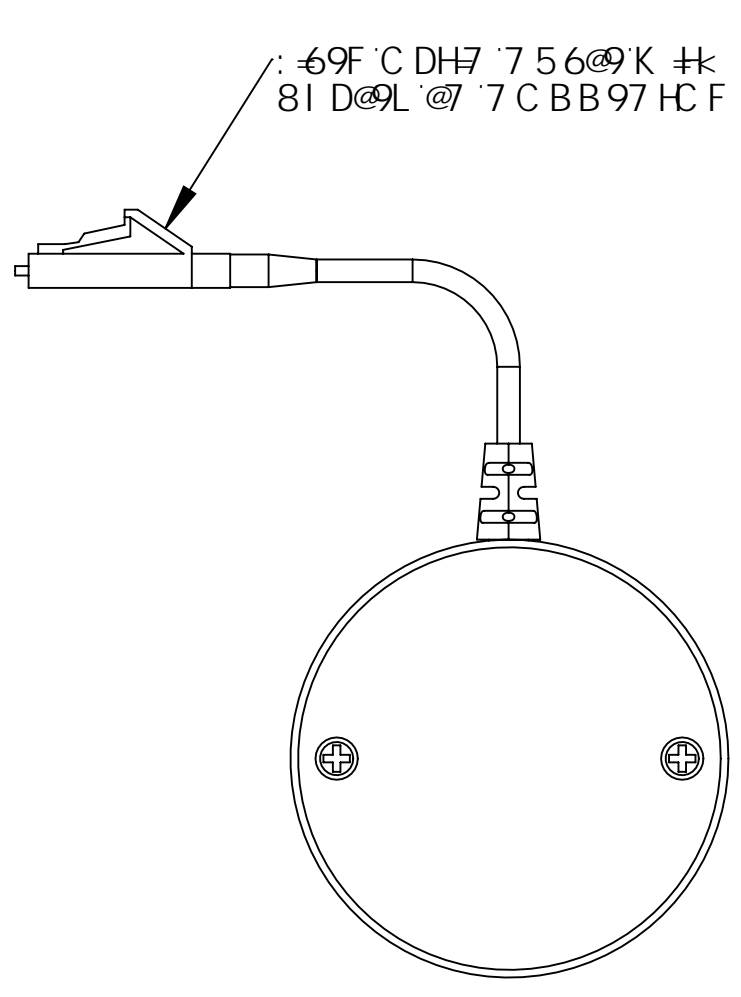
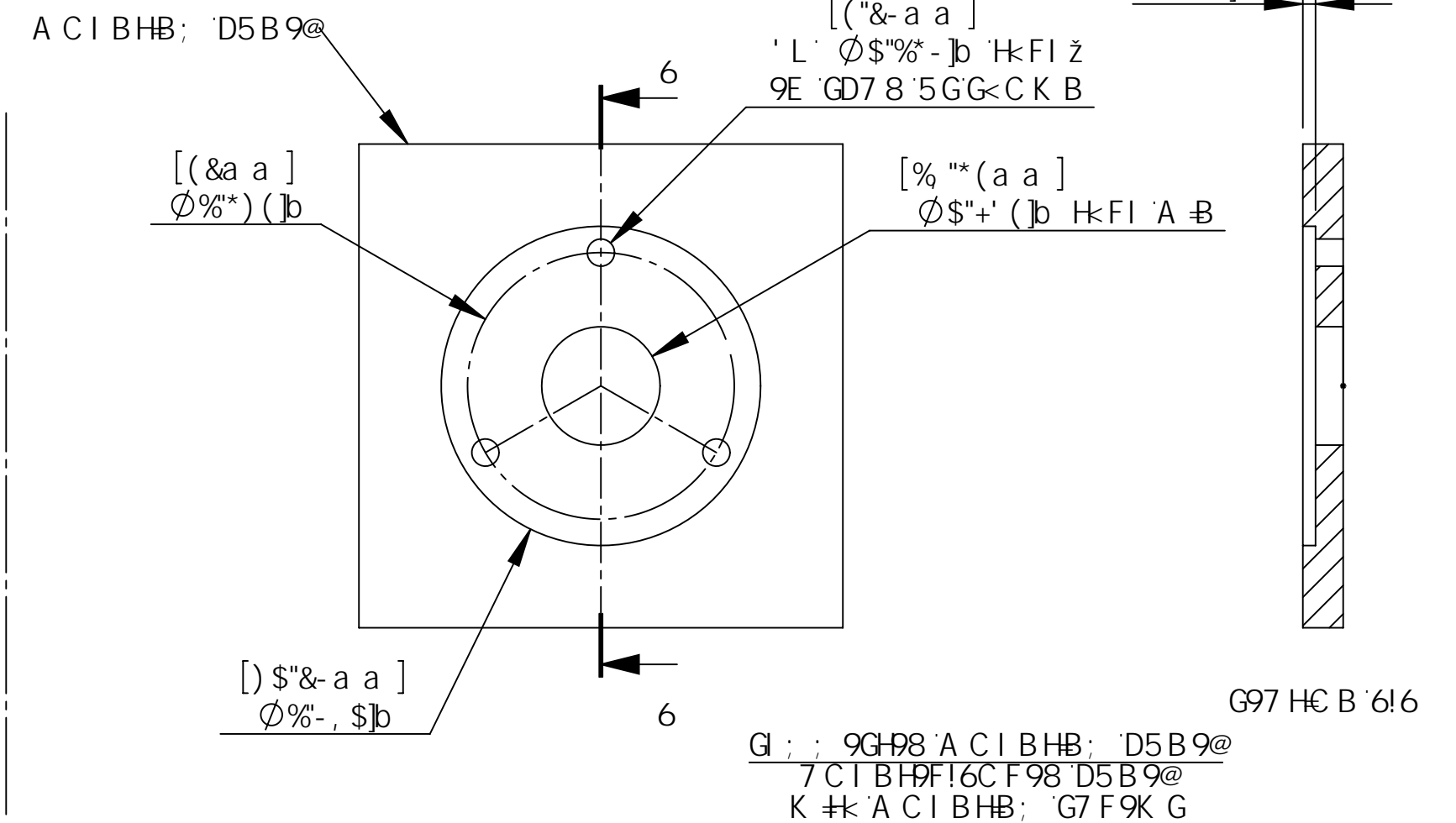
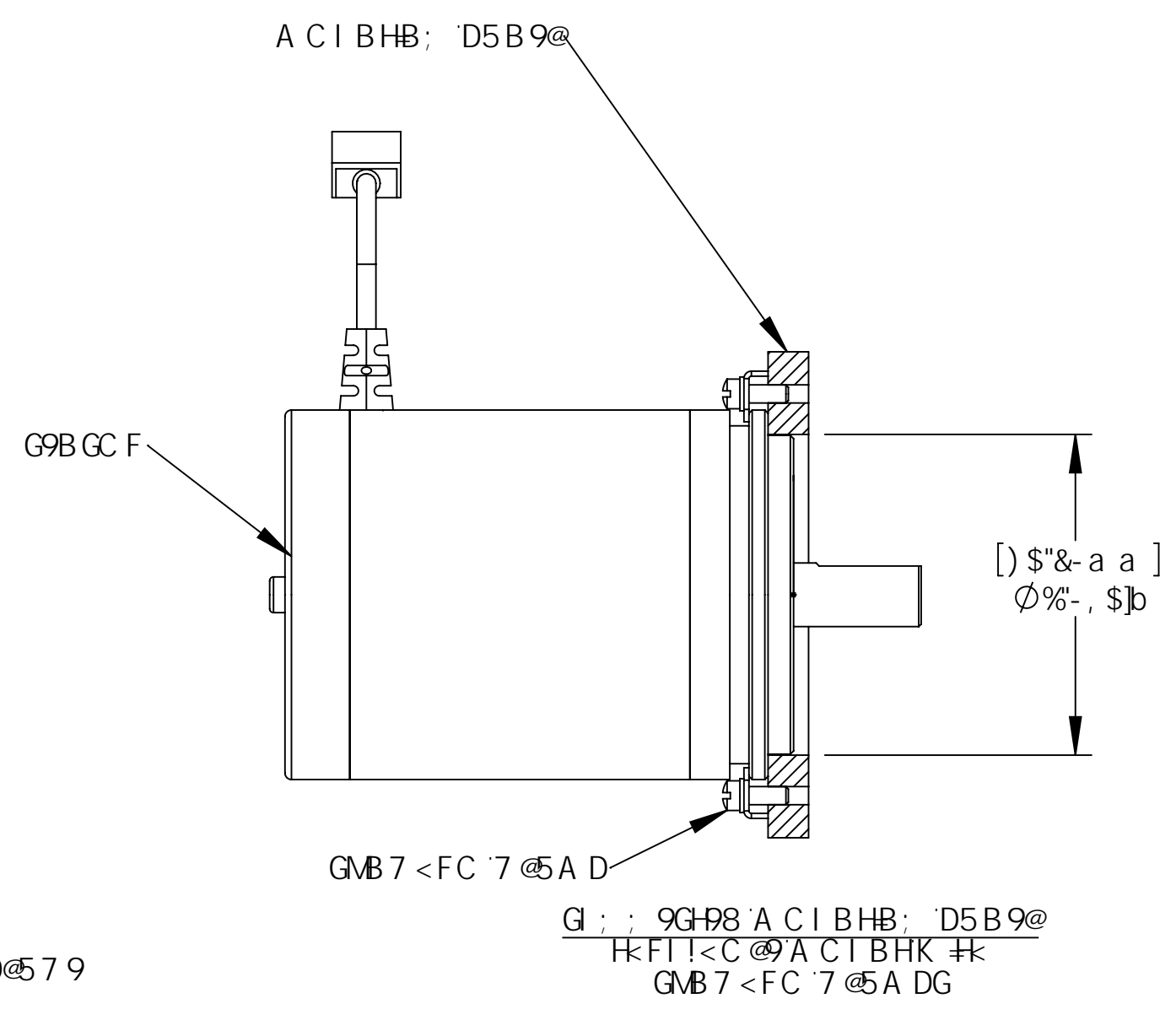

" "" K 5FB-B ; ? 99D 7 C BB97 HC F 7 C J 9FG-B D@5 7 9
 " " " 81 F-B ; G C F 5 ; 9 Z HC DFC H 7 H ; -69F C DH7
 " " " B H 9 F ; 5 7 9 G "

& " " K 5FB-B ; " " 8 C B C H 8 F C D 1 B # " 8 F C D D-B ;
 " " " C F C H K 9 F G 9 J 9 F 9 G < C 7 ? ' A D 5 7 H G
 " " " A 5 M 8 5 A 5 ; 9 I B # "

% " " 5 @ K 5 M G 1 G 9 ; @ L - 6 @ 7 C I D @ B ; K < 9 B
 " " " A C I B H B ; G < 5 : H H C 9 L H 9 F B 5 @ 9 E I D A 9 B H "

B C H 9 G I B @ G G C H K 9 F K - 6 9 G D 9 7 = 9 8

| | | | | |
|------------------------|---|-----------------------------------|----------------------|------------------|
| G<5: H7 C 8 9 G A 9 | $\phi 5$ | 6 @B; Hk | 7 : @H | 8 : @H @B; Hk |
| \$* | " & ') , \pm "\$\$\$ & Q " - , - \pm "\$\$) Q | " " - (\pm "\$ % \$ \phi % \$ Q | " & % * ' Q ") \$ Q | " " % ' Q Q |
| %\$ | " " - ' & \pm "\$\$\$ ' Q " - , \pm "\$\$ + * Q | " + , \pm "\$ % \$ \phi % \$ Q | " " + (' Q ") \$ Q | " * ' \$ Q % * Q |
| -) | " " + (* \pm "\$\$\$ ' Q ") % \pm "\$\$ + * Q | ")) \$ \pm "\$ % \$ \phi % \$ Q | " " (' Q " + * Q | " ((\$ Q % & Q |

| | | | |
|--|-------------------------------|-----------------|---|
| I B @ 9 G C H ; 9 K @ 9 Q 9 7 = 9 8 | B 5 A 9 | 8 5 H 9 | A 7 F C B C F ' B 7 " |
| B A 9 B G C B G S F 9 B ' B 7 < 9 G H C @ 9 F 5 B 7 9 G 5 B : I @ 5 F , \pm) * H C D @ 5 7 9 8 9 7 A 5 @ \pm \$ & H F 9 9 D @ 5 7 9 8 9 7 A 5 @ \pm \$ \$) : C I F D @ 5 7 9 8 9 7 A 5 @ \pm \$ \$)\$ | B F 5 K B | F 6 C M 9 F | B 9 K 6 I F M D 5 F 2 2 7 5 f l \$) \epsilon (- - ! \$ % \& (|
| B H F D F 9 H ; 9 C A 9 F 7 H C @ 9 F 5 B 7 B ; D 9 F | 7 < 9 7 7 9 8 | 9 8 : 5 D D F " | H H @ 9 |
| A 5 H F 5 @ !!! | A : : 5 D D F " | E 5 " | G 9 B G C F z 8 1 D @ L @ 7 ' D = H 5 @ |
| D F C D F @ 6 F M 5 8 8 7 C B ; 6 9 B 6 @ H 9 B : C F A 5 H C B 7 C B H B 9 8 ; B H G B F 5 K B : G H 9 G C @ 9 D F C D F H A C A 7 F C B C F 7 C F D C F 5 H C B ' 5 B M 9 0 F C 8 1 7 H C B ; B D 5 F H C F 5 G 5 K < C @ K H C I H H 9 K F H H B D F A G G C B C : A 7 F C B C F 7 C F D C F 5 H C B ; G D F C < 4 H 9 8 | 7 C A A 9 B H G | | G N 9 8 K ; " " B C " |
| | | | F 9 J |
| | | | 7 A F ' ' & ! L L 7 L L |
| | | | 5 |
| | B C B C H 7 5 @ 9 B F 5 K B ; | | G 7 5 @ 9 . % % K 9 # < H ' G < 9 9 H % C : % |

| | | | |
|----------|--------------|--------|-----------|
| F9J GCBG | | | |
| F9J | 89G7 F DHC B | 85H | 5DDFCJ 98 |
| 5 | B9K F9@95G9 | &l+!%& | F: 6 |

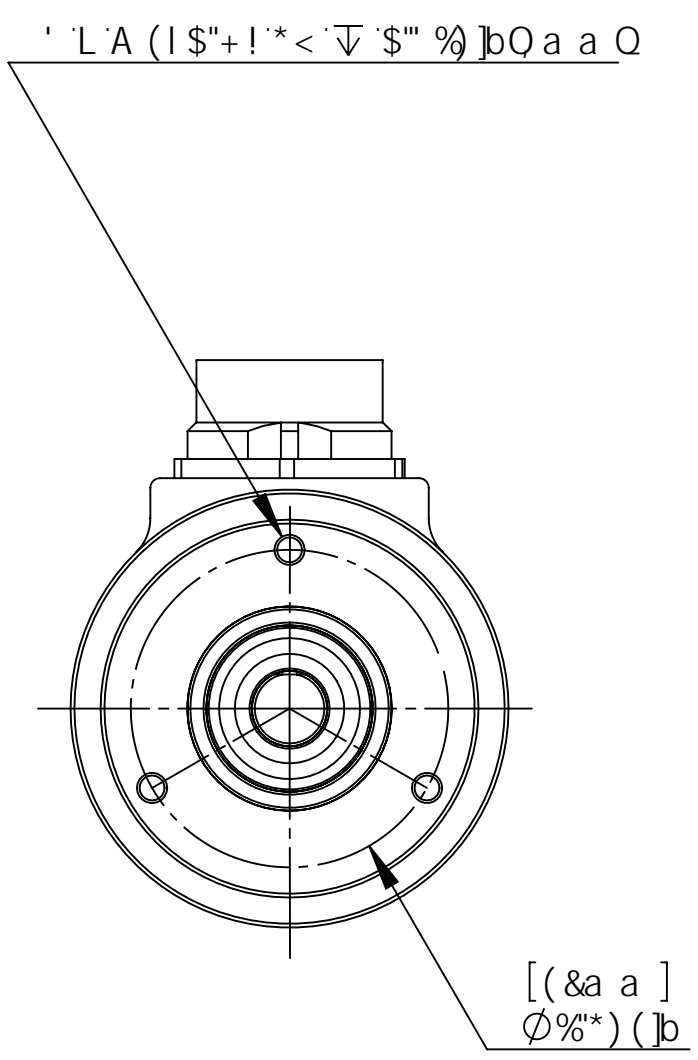
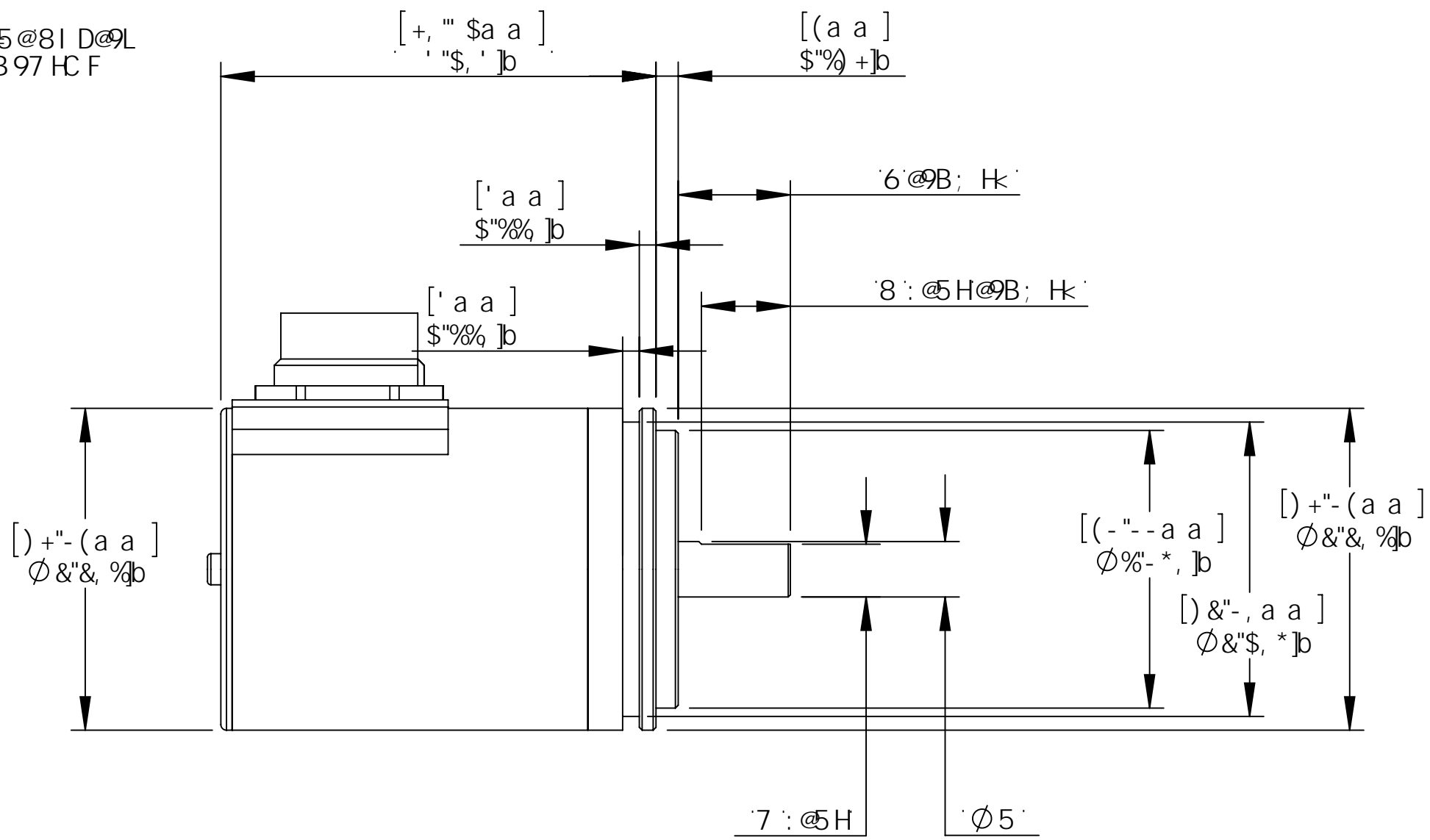
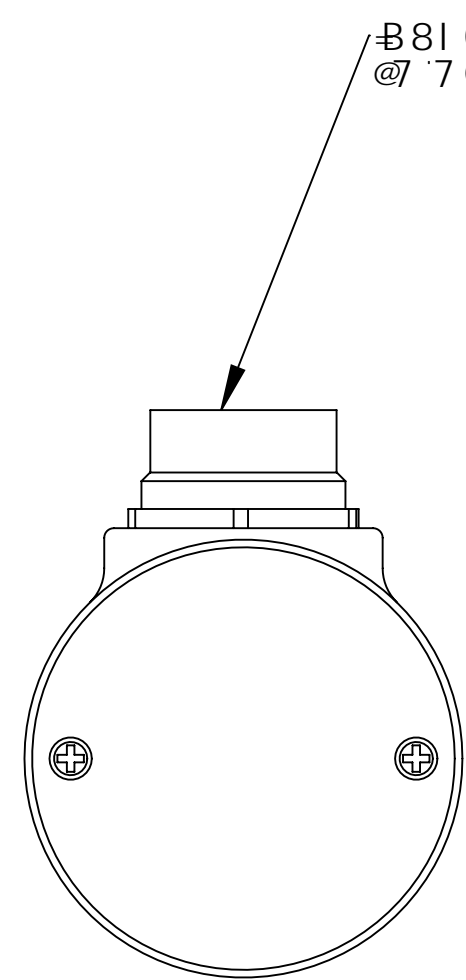

A F ' ' &! M % \$ ' 8 \$ \$ '

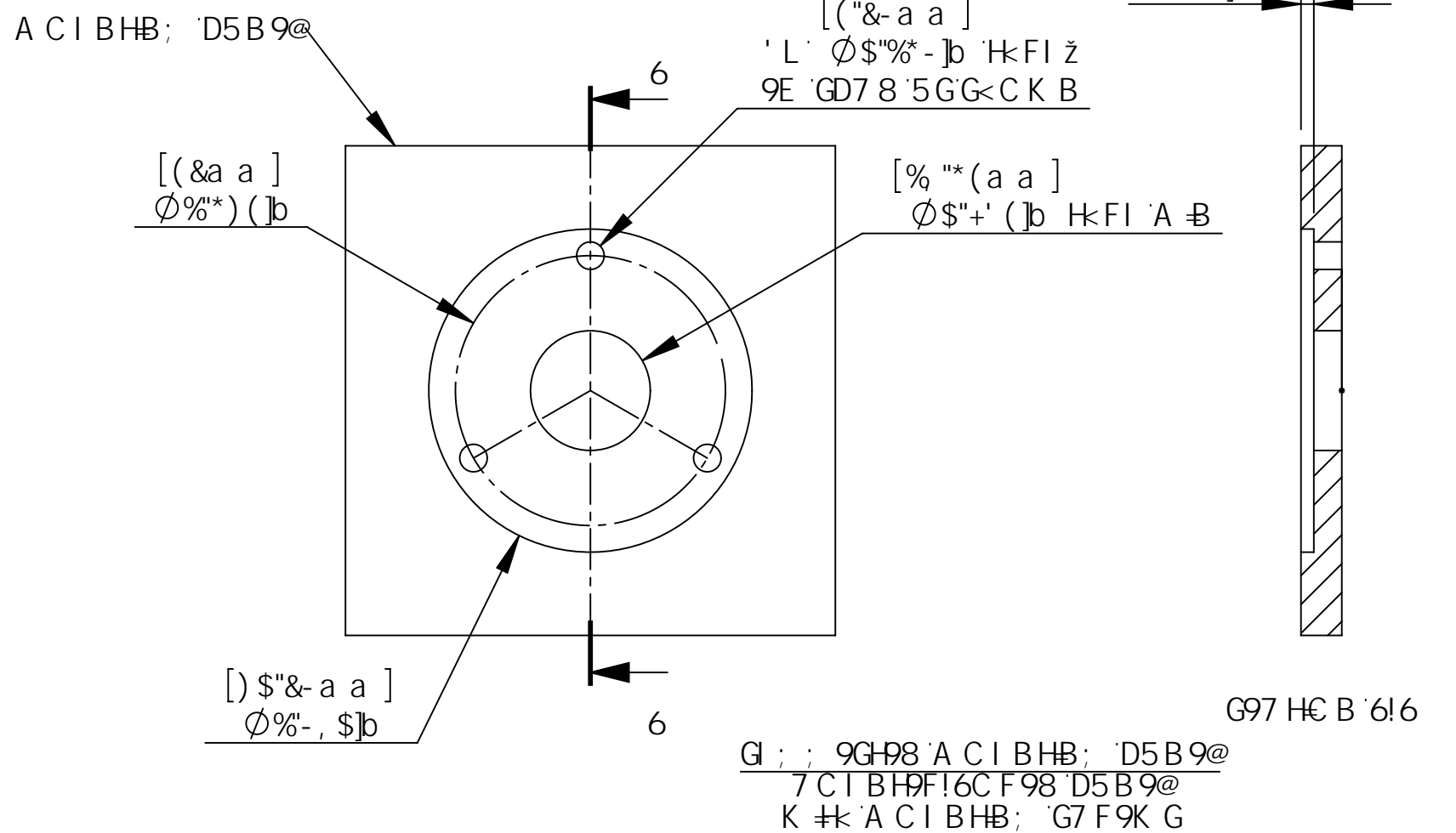
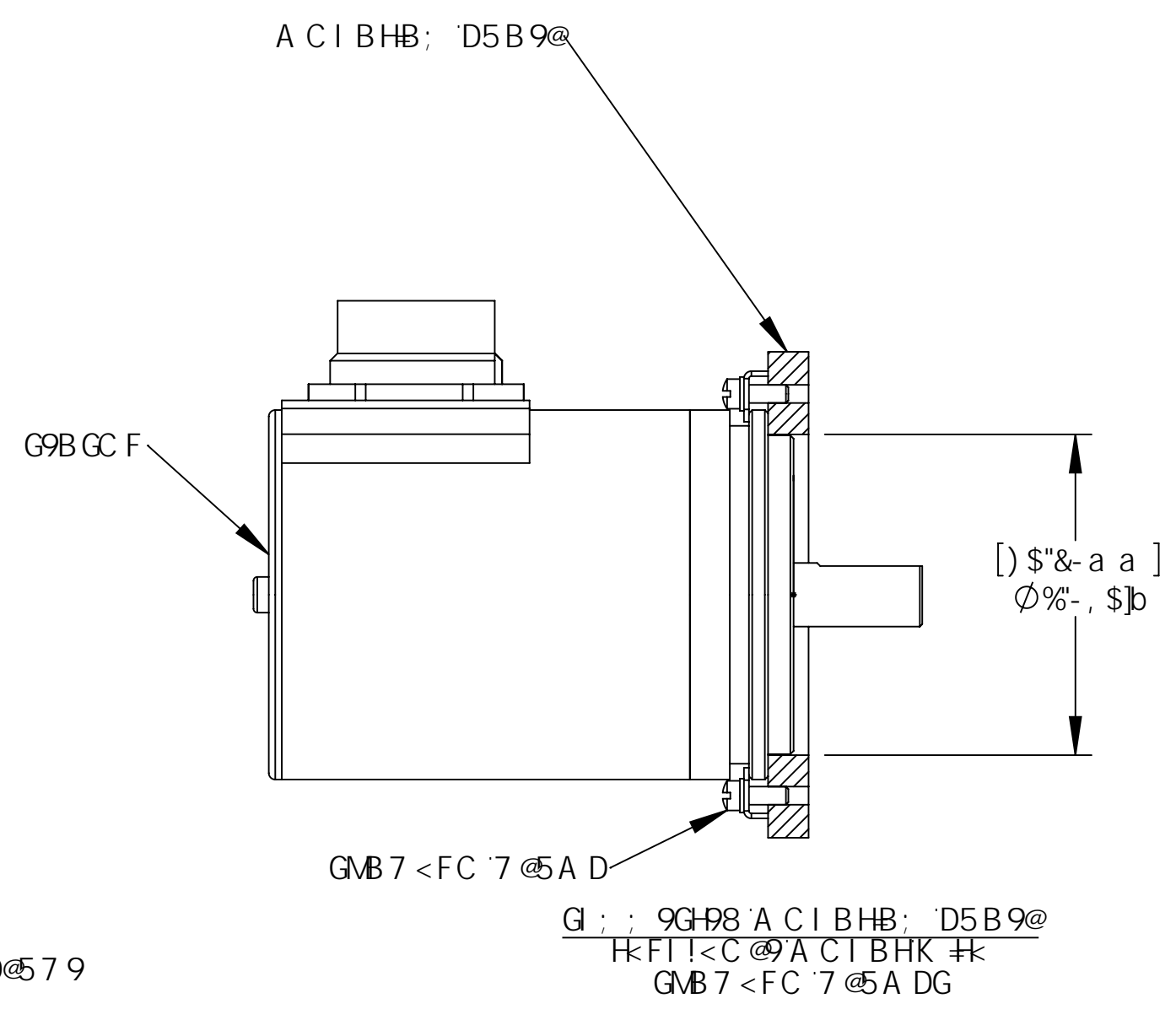
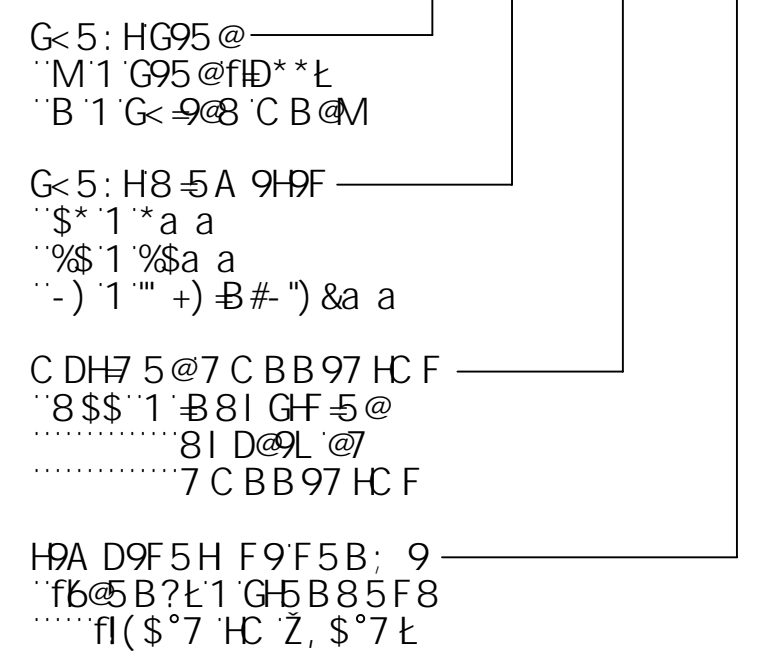

' " K 5 F B - B ; ? 9 9 D 7 C B B 9 7 H C F 7 C J 9 F G - B D @ 5 7 9
 " 8 I F - B ; G C F 5 ; 9 2 H C D F C H 7 H : - 6 9 F C D H 7
 " B H 9 F : 5 7 9 G "

& " K 5 F B - B ; " 8 C B C H 8 F C D 1 B # " 8 F C D D - B ;
 " C F C H K 9 F G 9 J 9 F 9 G < C 7 ? A D 5 7 H G
 " A 5 M 8 5 A 5 ; 9 I B # "

% " 5 @ 5 M G I G 9 : @ L 6 @ 7 C I D @ B ; K < 9 B
 " A C I B H B ; G < 5 : H H C 9 L H 9 F B 5 @ 9 E I D A 9 B H "

B C H 9 G I B @ G G C H K 9 F K - 6 9 G D 9 7 = 9 8

| | | | | |
|-------------------|---|-----------------------------|----------------------|--------------------|
| G<5: H7C89 GAG | Ø5 | 6 @ 9B; Hk | 7 : @ 5H | 8 : @ 5H @ 9B; Hk |
| \$* | " & ') , ± "\$\$\$ & Q " - , - ± "\$\$) Q | " - (± "\$% \$ Q % \$ Q | " & % * ' Q ") \$ Q | " " % ' Q Q |
| % \$ | " - ' & ± "\$\$\$ ' Q " - , ± "\$\$ + * Q | " + , ± "\$% \$ Q % \$ Q | " + (' Q ") \$ Q | " * ' \$ Q % * Q |
| -) | " + (* ± "\$\$\$ ' Q ") % ± "\$\$ + * Q | ")) \$ ± "\$% \$ Q % \$ Q | " (' Q " + * Q | " ((\$ Q % % & Q |

| | | | | |
|---|---|---------------------------------------|-------------------------------|---|
| I B @ 9 G C H K 9 F K @ 9 D 9 7 = 9 8 8 A 9 B G C B G 5 F 9 B B 7 < 9 G H C @ 9 F 5 B 7 9 G 5 B : 1 @ 5 F . ±) * H K C D @ 5 7 9 8 9 7 A 5 @ ± \$ & H F 9 9 D @ 5 7 9 8 9 7 A 5 @ ± \$ \$: C I F D @ 5 7 9 8 9 7 A 5 @ ± \$ \$ \$ | 8 F 5 K B 7 < 9 7 9 8 9 8 : 5 D D F " | B 5 A 9 F 6 C M 9 F & l + ! % & | 8 5 H 9 E 5 " | A 7 F C B C F B 7 " B 9 K 6 I F M D 5 F 2 7 5 f l) L (- - ! \$ % &) H H 9 9 G 9 B G C F z B 81 G F - 5 @ 81 D @ L @ 7 C B B 9 7 H C F G 9 7 H C B 6 I 6 G 7 5 @ 9 . % % K 9 # < H ' G < 9 9 H % C : % |
| D F C D F @ 6 F M 5 8 8 7 C B : 6 9 8 H 6 @ H 9 B : C F A 5 H C B 7 C B H 6 B 9 8 : B H G 8 F 5 K B : G H 9 G C @ 9 D 9 7 = 9 8 A 7 F C B C F 7 C F D C F 5 H C B : 5 8 M 9 0 F C 81 7 H C B : B D 5 F H C F 5 G 5 K < C @ K H C I H H 9 K F H H B D 9 F A G G C B C : A 7 F C B C F 7 C F D C F 5 H C B : G D F C < 4 4 8 8 | A 5 H F 5 @ !!! B 6 G !!! | 7 C A A 9 8 H G | 8 C B C H 7 5 @ 9 8 F 5 K B : | 7 A F ' ' & ! L L 8 \$ \$ 5 |