

FIBER OPTIC INCREMENTAL ENCODER

MR340-1 DIN Rail Mount Controller

MR340 SERIES

The MR340-1 Din Rail Mount Controller is the active optical and electrical interface for the MR340 Series ZapFREE® Fiber Optic Incremental Encoder System. The system is an innovative all-optical design immune to any electro-magnetic interferences such as magnetic fields, lightning, voltage, and other harsh environment conditions.



As the incremental code passes through an MR34X Sensor's internal optical pick-up, the phase output of two light beams creates the classical A/B quadrature signals accessible via the controller's electrical interface.

The controller keeps track of position and also calculates the RPM and speed of the connected encoder. Both position and speed can be read via RS485 Modbus RTU serial interface, USB, SSI or analog output. The analog output can be configured for either $\pm 10V$ or 4-20mA output.



U.S. Patent 7,196,320
Inherently Safe Optical Radiation
For EPL Mb/Gb/Gc/Db/Dc

Features

- Supports all MR340 series rotary and linear sensors
- Mounts on standard 35mm DIN Rail
- Operates from 24 VDC
- Interference-free transmission up to 2000 meters

Interfaces

- Programmable line driver quadrature outputs: 5V, 12V, or 24V
- Encoder links up to 2000 meters
- Programmable analog output: $\pm 10V$ or 4-20mA
- SSI and USB or RS485/Modbus RTU Interface

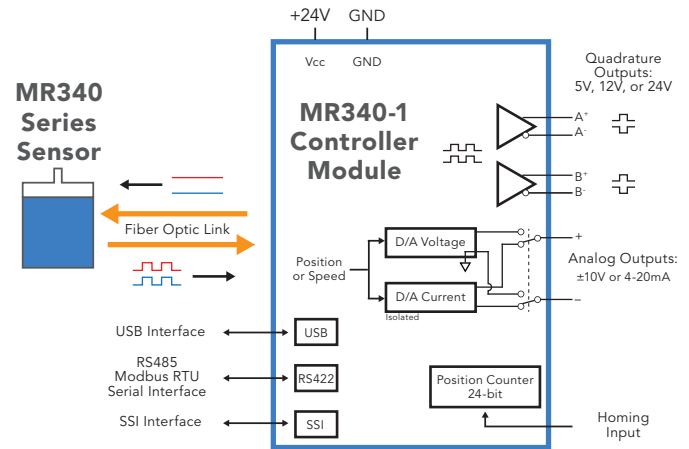

System Planning

MR340-1 Controller

Inherently Safe Optical Radiation

MR340 Series Sensors

Simple Mechanical Device

Electrical Connections:
24 VDC Power, A/B Quadrature Output
Analog Output, RS485, SSI, USB

MR343 MR341 MR348 MR342 MR344 MR346 MR345



Duplex LC and ODVA IP-LC
Multimode 62.5/125, Fiber Optic Cabling

MR340-1 Controller

Specifications

Electrical Interface	
NOTE: Electrical connections shall not exceed 3 meters	
Connectors	Electrical connections (J1) via Terminal Plug, Phoenix 1803659 (one supplied with Controller) USB (J2) via Type B receptacle SSI/RS485 (J3) via Hirose 3250-10P-C(50) plug (available separately)
Quadrature Outputs	A+/A-/B+/B- line driver outputs are user configurable: 5V, 12V, 24V; 100 kHz maximum bandwidth
Discrete Digital Signal	HOMING Input (24V)
Digital Interfaces	SSI, USB, and RS485/Modbus RTU
Analog Output	User selectable: $\pm 10V$ or 4-20mA, Position or Speed Mode Current Range=0-20mA, Max burden resistance=500 Ω (24V supply), Accuracy=0.25% F.S. Voltage Range= $\pm 10V$, Max current=5mA (2k Ω load), Short circuit<5s, Accuracy=0.25% F.S. Position Mode: Full scale range is 1 to 8,388,607 counts (equivalent to >8,192 revolutions of a 1024ppr encoder) based on contents of internal counter. Either Homing Input (+24V) or software command may be used as a Homing command to set absolute position. Speed Mode: Full scale range can be programmed from 10 to 10,000 RPM
Power Supply	+24 VDC, 50mA (typical); Operates over 18V to 28V During power-up, external power supply should be capable of 100mA in-rush current
Optical Interface	
Optical	Dual Wavelength, 850nm/980nm, Class I Eye Safe
Fiber	LC Duplex, 62.5/125 μ m Graded Index Fiber, 0.275 NA, Type OM-1
System Loss Budget	12dB Round Trip
Maximum Distance	Up to 2000 meters (6560 ft) with MR340 series Sensor
Explosive Atmospheres	
Inherently Safe Optical Radiation	
EX Classification	Controller shall be installed in non-hazardous location only Power supply shall be current limited to 200mA
ATEX	ce [Mb/Gb/Gc/Db/Dc]
EAEU/GOST	[Mb/Gb/Gc/Db/Dc]
IEC Ex	[Mb/Gb/Gc/Db/Dc]
North America	Controller shall be installed in non-hazardous location only
Environmental Attributes	
Temperature/Humidity	-5°C to +55°C (23°F to +131°F), 0-95% RH, Non-Condensing
Ingress Protection	IP30, Keep free from contaminants
Physical Attributes	
Mounting	35mm DIN rail or screw mount
Dimensions	114 x 89 x 32 mm (4.5 x 3.5 x 1.25 inches)
Weight	260 g (9 oz)

Specifications subject to change without notice

Front View

J1 - Discrete Power/Signal Interface
Duplex LC Optical Interface



Bottom View

J2 - USB Interface
J3 - SSI/RS485 Interface

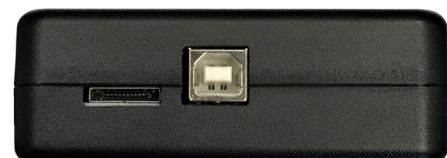

MR340-1 Controller

J1 - Discrete Power/Signal Interface

J1 Electrical Interface via Terminal Plug Phoenix 1803659 (one supplied with Controller)		
Pin	Function	Notes
1	+24V	+24V Power Supply (typical 50mA)
2	GND	GND
3	HOMING INPUT	+24V Digital Input NOTE: Function is determined by user setting of Reset Mode 0x209. Typically used as HOMING Input to set absolute position of encoder.
4	GND	GND, Connected to Pin 2
5	SIG+	User Selectable Analog Output: $\pm 10V$ or 4-20mA
6	SIG-	NOTE: Either supplied ZAPPY® software or user software is used to set Electrical Mode, Functional Mode (Position or Speed), Scale and Filter.
7	A+	User Selectable Quadrature Output Level: 5V, 12V, 24V NOTE: Supplied ZAPPY® software or user software is used to set A/B output levels.
8	A-	
9	B+	
10	B-	

J2 - USB Interface

J3 - SSI/RS485 Interface

J3 Electrical Interface via Plug Hirose 3240-10P-C(50) Pigtail Assembly available as Micronor MR430-99-01			
Pin	RS485	SSI	MR4430-99-01 Wire Color
1	+5V	+5V	Brown
2	RCV- (RS422 Input)		Red
3	RCV+ (RS422 Input)		Orange
4	TX- (RS422 Input)		Yellow
5	TX+ (RS422 Input)		Green
6	GND	GND	Blue
7		SSI CLK-	Purple
8		SSI CLK+	Grey
9		SSI DAT-	White
10		SSI DAT+	Black

NOTE: +5V can be used to power a RS485-to-RS232 converter module.

Ordering Info

MR340 - 1

DIN Controller

Quick Ship Configurations:

MR340-1	DIN Rail Mount Controller
MR430-99-01	J3 Pigtail Assembly, Length=1m, for SSI and RS485 interface connection

Compatible Sensors:

MR341	Size 11 Mini Rotary Encoder
MR342	Size 58 Standard Rotary Encoder
MR343	MRI Safe, Linear Encoder
MR344	High Resolution, Hollow Shaft Encoder
MR345	High Resolution, Shafted Encoder
MR346	Heavy Duty, IP66 Encoder
MR348	MRI Safe, Rotary Encoder

MICRONOR INC, 900 Calle Plano, Suite K
Camarillo, CA 93012 USA
T +1 805 389 6600 F +1 805 389 6605
sales@micronor.com www.micronor.com

MICRONOR AG, Pumpwerkstrasse 32
CH-8105 Regensdorf, Switzerland
T +41 44 843 4020 F +41 44 843 4039
sales@micronor.ch www.micronor.com