

| REVISIONS | | | | |
|-----------|---------|---------|----------|----------------|
| REV | DATE | ECN NO. | DRAWN BY | DESCRIPTION |
| A | 1-26-18 | N/A | RGB | MR328 TO MR348 |

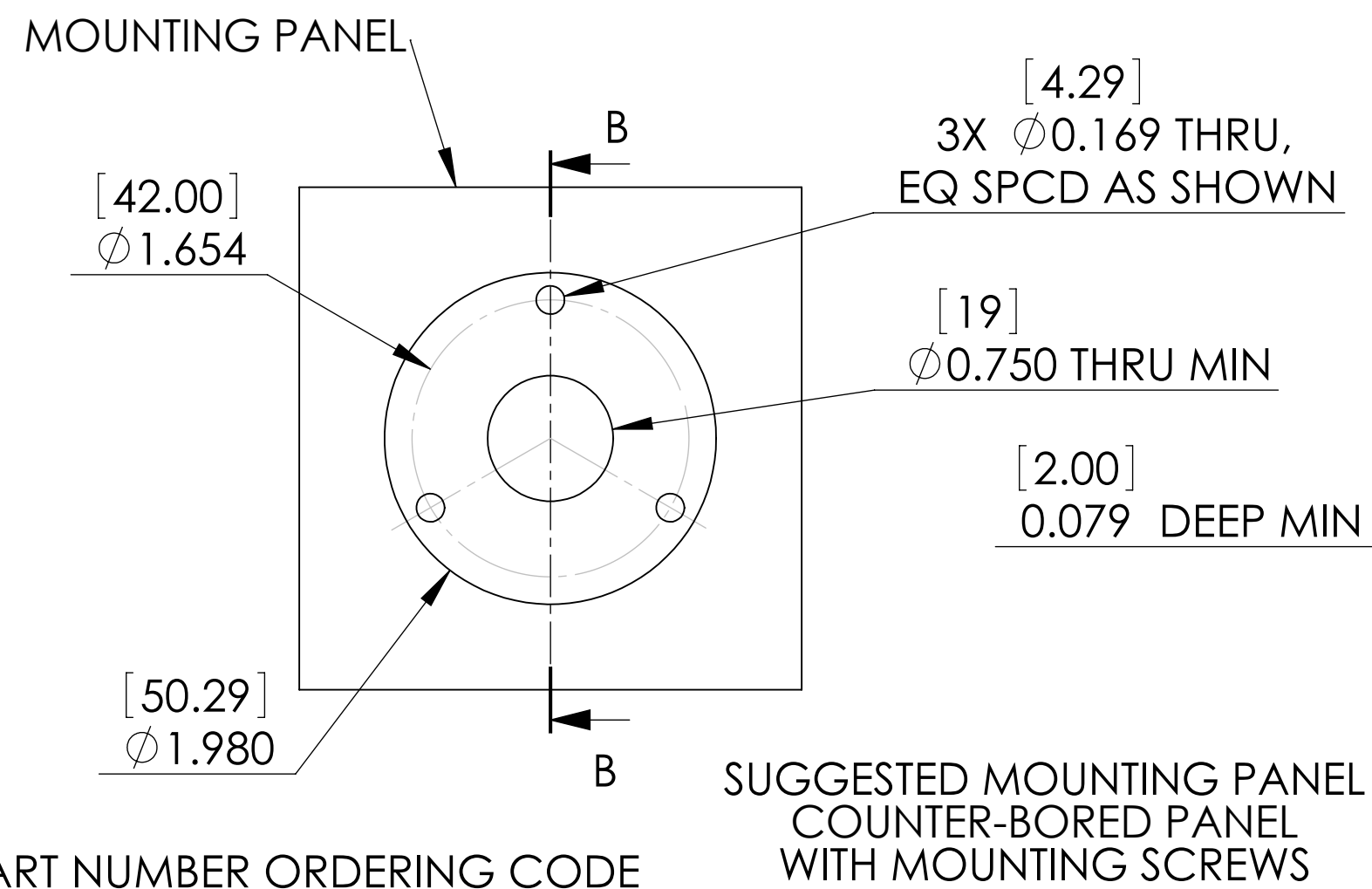
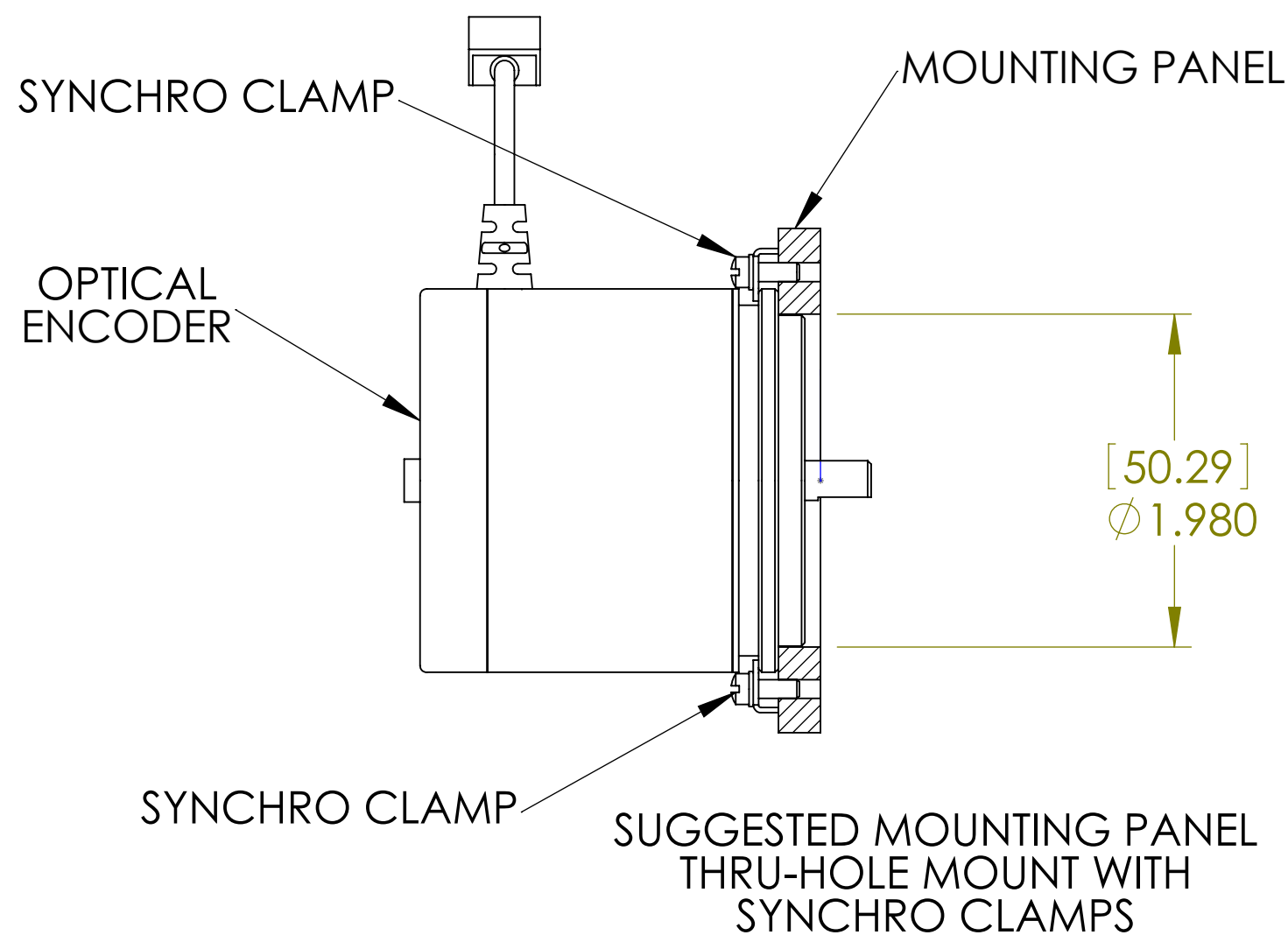
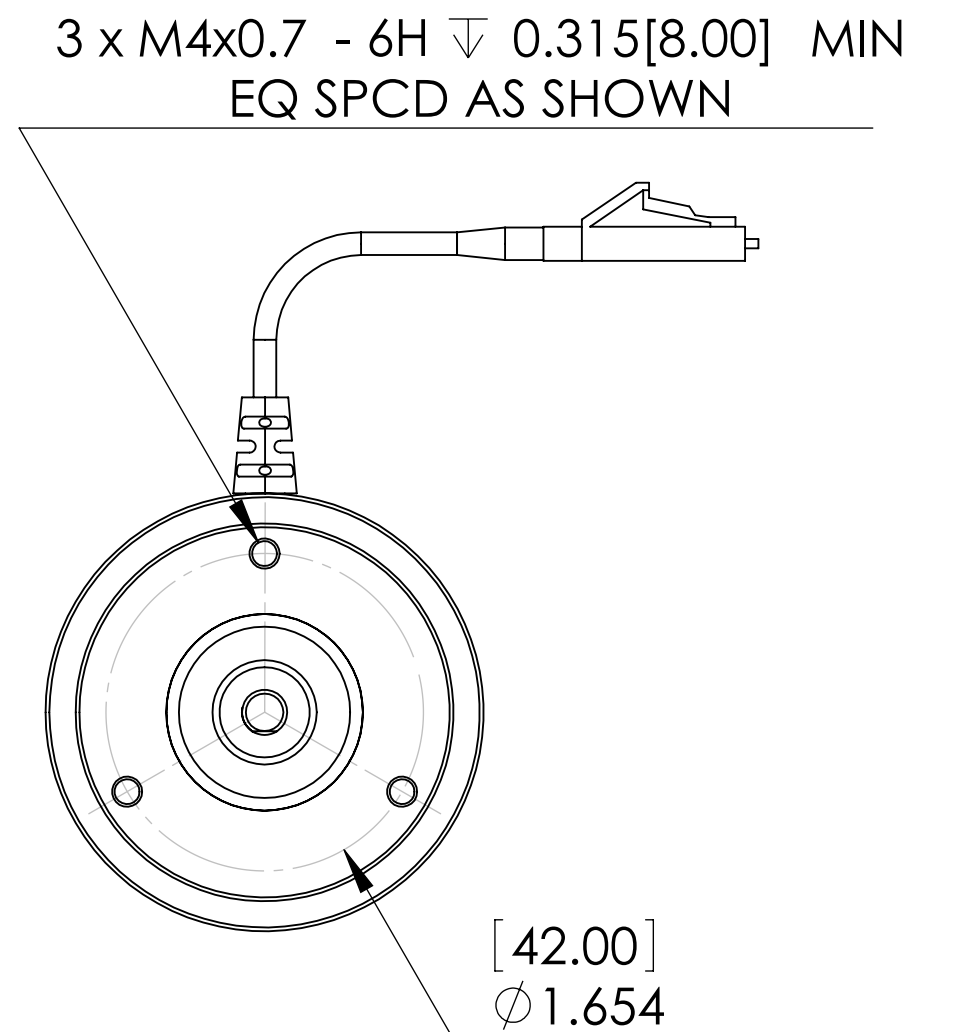
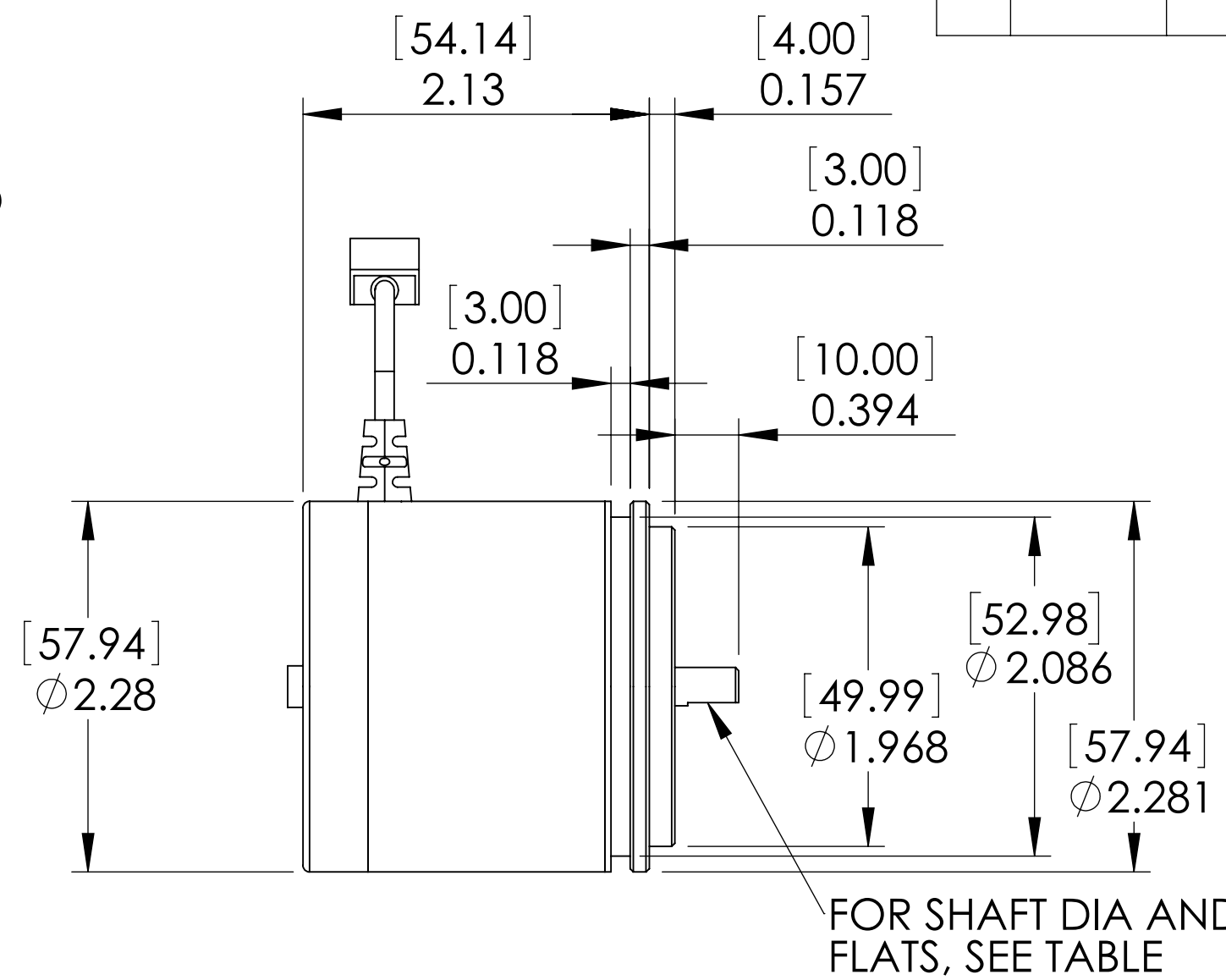
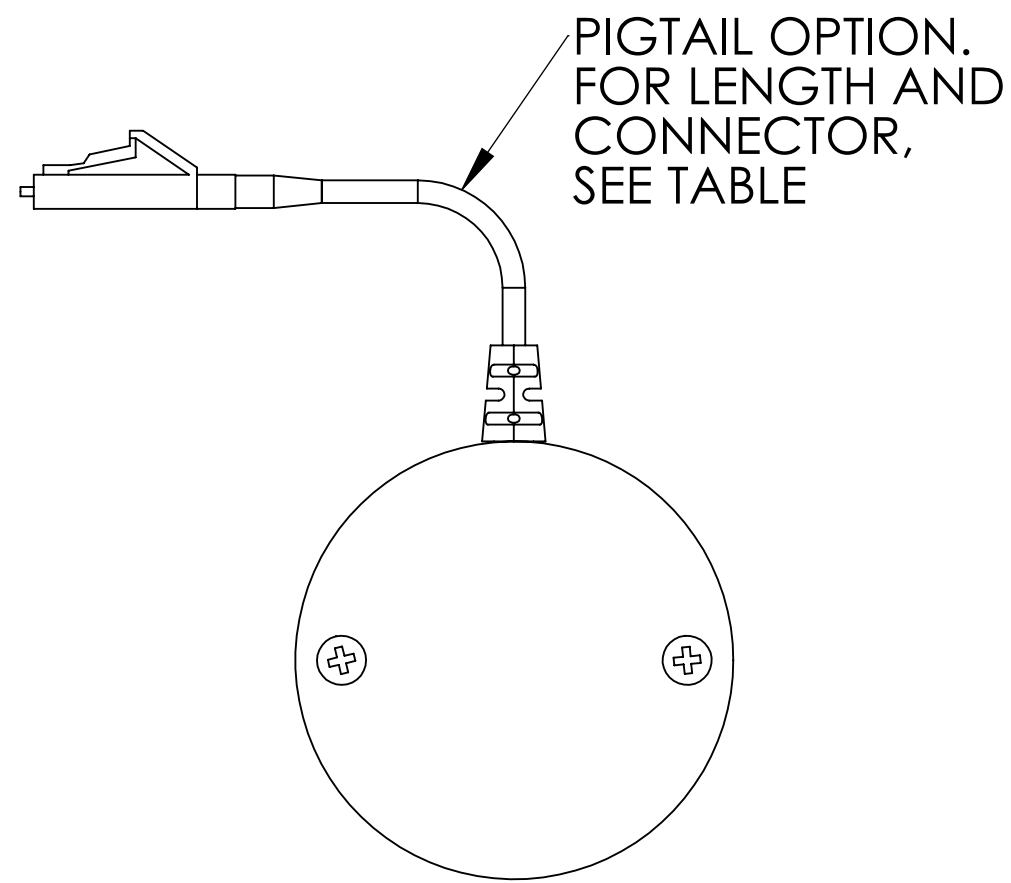

3. WARNING: KEEP CONNECTOR COVERS IN PLACE DURING STORAGE, TO PROTECT FIBER OPTIC INTERFACES.
2. WARNING: DO NOT DROP UNIT. DROPPING OR OTHER SEVERE SHOCK IMPACTS MAY DAMAGE UNIT.
1. ALWAYS USE FLEXIBLE COUPLING WHEN MOUNTING SHAFT TO EXTERNAL EQUIPMENT.

NOTES: UNLESS OTHERWISE SPECIFIED

PART NUMBER ORDERING CODE

MR348 - D 06 C 05

RESOLUTION
D = 360

PIGTAIL LENGTH IN METERS
05 = 5 METERS
10 = 10 METERS

SHAFT SIZE IN MILLIMETERS
6 = 6MM SHAFT
(Ø 0.2358 ± .0002 [5.989 ± 0.010] WITH 0.216 [5.50 FLAT])

CONNECTOR TYPE
C = DUPLEX LC

OTHER SHAFT OPTIONS ARE AVAILABLE

PROPRIETARY AND CONFIDENTIAL
THE INFORMATION CONTAINED IN THIS DRAWING IS THE SOLE PROPERTY OF MICRONOR INC. ANY REPRODUCTION IN PART OR AS A WHOLE WITHOUT THE WRITTEN PERMISSION OF MICRONOR INC. IS PROHIBITED.

UNLESS OTHERWISE SPECIFIED:
DIMENSIONS ARE IN INCHES

TOLERANCES:
TWO DECIMAL PLACE: ±.01
THREE DECIMAL PLACE: ±.004
FOUR DECIMAL PLACE: ±.0010
ANGULAR: ±.5°

MATERIAL: SEE NOTES
FINISH: SEE NOTES
DO NOT SCALE DRAWING

micronor FIBER OPTIC KINETIC SENSORS
WWW.MICRONOR.COM
805 389 6600

TITLE:
MR348 MRI COMPATIBLE
ROTARY INCREMENTAL
ENCODER ENVELOPE

| | | |
|--------|------------|---------------|
| SIZE | DWG. NO. | REV |
| C | 98-0340-58 | A |
| SCALE: | 1:1 | SHEET: 1 OF 1 |