



MR361 Series Fiber Optic Transmission Link For Incremental Encoders Data Sheet and User Guide

Doc No: 98-0361-01
Revision D1, Released 01/13/2022



MICRONOR SENSORS
2085 Sperry Ave, Suite A-1
Ventura, CA 93003 USA
Tel +1-805-389-6600
Fax +1-805-389-6605
sales@micronor.com
www.micronor.com

For Sales & Support in Europe:

MICRONOR AG
Pumpwerkstrasse 32
CH-8105 Regensdorf
Switzerland
Tel +41-44-843-4020
Fax +41-44-843-4039
sales@micronor.ch
www.micronor.ch

Notice of Proprietary Rights

The design concepts and engineering details embodied in this manual, which are the property of MICRONOR SENSORS and MICRONOR AG, are to be maintained in strict confidence; no element or detail of this manual is to be spuriously used, nor disclosed, without the express written permission of MICRONOR SENSORS. All rights are reserved. No part of this publication may be reproduced, stored in a retrieval system, or transmitted in any form or by any means, electronic, mechanical, photocopying, recording, or otherwise, without prior written permission from MICRONOR SENSORS.

Revision History

Revision	Date	Notes
A	8/11/2014	Original Release (English), Author: DNH/Micronor Inc.
B	5/5/2015	Part Number Correction 9770.30.170 should be 9770.30.160
C	10/15/2015	Updated with new Camarillo address, tel/fax
D	08/29/2016	Updated appearance
D1	1/13/2022	Updated company reference to Micronor Sensors

File Name

98-0361-01_D1_MR361 Manual_Released_13Jan2022.docx

Table of Contents

1.	Product Description.....	4
1.1.	Fiber Optic Transmission Link for Incremental Encoders.....	4
1.2.	Fields of Application	4
1.3.	Features	5
2.	Ordering Information.....	6
3.	Standard Contents	7
4.	Installation and Operation	8
4.1.	Mounting Modules on DIN Rail.....	8
4.2.	Fiber Optic Connections to the Modules.....	9
4.3.	Electrical Connections to the Module	10
4.4.	System Start-Up & Performance Check.....	11
5.	Troubleshooting	12
5.1.	Potential Issues & Solutions	12
5.1.1.	XMTR Power Green LED not ON when controller powered.....	12
5.1.2.	RCVR Link Status LED not ON when controller powered	12
5.1.3.	RCVR Link Status LED Blinks	12
5.1.4.	RCVR Encoder Outputs not working but both LEDs On.....	12
5.2.	Damaged In Shipment	12
6.	Warranty Information.....	13
7.	Specifications	14
8.	Theory of Operation.....	15
9.	Applications	16
9.1.	Using unused XMTR inputs for signaling inputs.	16
10.	Mechanical Reference Drawing	17

Table of Figures

Figure 1.	MR361 Series Fiber Optic Link shown in use with 24 VDC HTL/Push-Pull Incremental Encoder and Medium Voltage Drive	4
Figure 2.	Modules mount on standard 35mm DIN rail	8
Figure 3.	Close up of DIN rail adapter on module	8
Figure 4.	ST Optical Interface on Module	9
Figure 5.	Module shown with supplied Phoenix Combicon® Wiring Plugs	9
Figure 6.	How to terminate XMTR inputs or RCVR outputs	11
Figure 7.	Meaning of Status LED on XMTR and RCVR Modules.....	11
Figure 8.	Theory of Operation of MR361 Fiber Optic Encoder Link System	15
Figure 9.	How to use unused XMTR inputs for signaling inputs	16

1. Product Description

1.1. Fiber Optic Transmission Link for Incremental Encoders

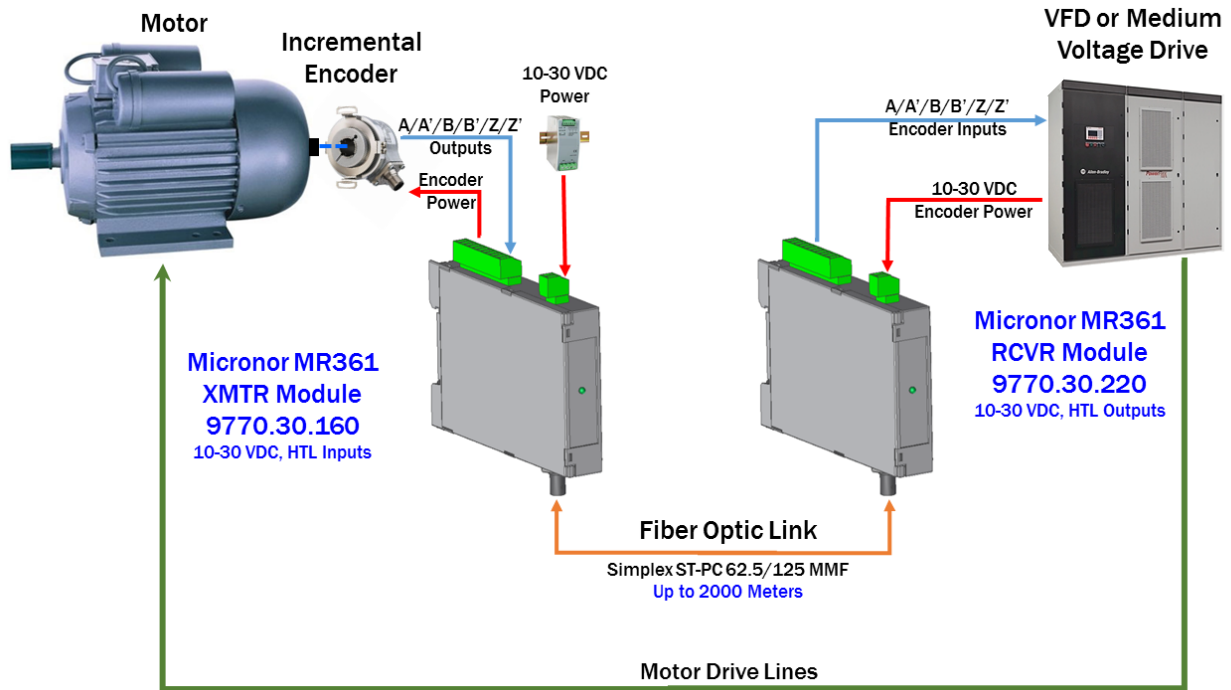

Figure 1. MR361 Series Fiber Optic Link shown in use with 24 VDC HTL/Push-Pull Incremental Encoder and Medium Voltage Drive

The MR361 series Fiber Optic Transmission Link System increases the reach of conventional electronics-based rotary and linear incremental encoders up to distances of 2000 meters via a fiber optic link. This solution allows clean optical transmission of sensitive encoder signals over long distances, through noisy electrical areas or when routed in parallel with noisy VFD or High Voltage motor drive lines. The system works with both optical and magnetic encoders and operates with complete transparency to the motion control or motor drive system.

The system consists of a fiber optic transmitter (XMTR) and fiber optic receiver (RCVR) module. The XMTR module multiplexes the user's encoder's quadrature output signals of the encoder into a light signal. A simplex multimode fiber optic link transports the optical signal to the RCVR module which then demultiplexes the optical signal back into the individual quadrature signals for connection to the encoder input of the motor drive or motion control system.

1.2. Fields of Application

- Long distance extension of encoder link through noisy environments
- Interference-free feedback for VFD and Medium/High Voltage drive systems
- Industrial: Oil & gas, mining/extracting, refining, steel mills
- Medical

1.3. Features

- DIN rail mount XMTR and RVCR modules
- Models for +5 VDC or +10-30 VDC Encoders
- Models for RS422 (TTL) or HTL/Push-Pull line drive circuits
- EMI/RFI immune fiber optic transmission link
- Encoder Link can reach up to 2 km
- Wide System Loss Budget
- Can support 2 encoders if Index not used

2. Ordering Information

Encoder Types	XMTR Module P/N	RCVR Module P/N
<u>Encoder Type 1</u> +5 VDC Input Power RS422 Differential Line Driver Outputs Up to 4 Channels A+/A-/B+/B-/C+/C-/D+/D-	9770.30.100	9770.30.200
<u>Encoder Type 2</u> +10-30 VDC Input Power RS422 Differential Line Driver Outputs Up to 4 Channels A+/A-/B+/B-/C+/C-/D+/D-	9770.30.140	9770.30.210
<u>Encoder Type 3</u> +10-30 VDC Input Power HTL or Push-Pull Differential Line Driver Outputs Up to 4 Channels A+/A-/B+/B-/C+/C-/D+/D-	9770.30.160	9770.30.220

Note: The XMTR and RCVR modules do not have to be for the same encoder type. Specifying a different RCVR module allows adapting signals to mismatched equipment/encoder interfaces. This is not a recommended practice but is a solution for those applications where the actual Encoder is incompatible with the downstream Encoder Interface on the motor drive.

Industrial grade ST-to-ST simplex cable assemblies may be specified using the ordering code MR320-M06Txx where xx is the length in meters.

3. Standard Contents

For a complete transmission system, be sure to order both XMTR and RCVR modules:

- XMTR module as ordered
- RCVR module as ordered
- MR321A 2.5mm fiber optic cleaning kit (one per order)
- Instruction Manual (this document, one hard copy per order)

4. Installation and Operation

4.1. Mounting Modules on DIN Rail



Figure 2. Modules mount on standard 35mm DIN rail

Per [Figure 2](#), first clip the fixed (white side) mount into one side of DIN rail. Then snap the black, spring-loaded end into place.



Figure 3. Close up of DIN rail adapter on module

4.2. Fiber Optic Connections to the Modules

The MR361 modules feature a bayonet-style ST-PC optical interface. Be sure that the ST plug end face is clean before being installed into the ST receptacle. Be sure to align the key on the plug with the slot on the receptacle before beginning to insert the connector.



Figure 4. ST Optical Interface on Module



Figure 5. Module shown with supplied Phoenix CombiCon® Wiring Plugs

4.3. Electrical Connections to the Module

As shown in *Figure 5*, both the XMTR and RCVR modules feature modular Phoenix Combicon® screw-type wiring plugs for making electrical connections to the XMTR/RCVR module and encoder. Two plugs (J1 and J2) are supplied with each module:

- J1, 2C plug for power connection to module (Phoenix 1840366)
- J2, 11C plug for encoder connections (encoder power and quadrature outputs, Phoenix 1840450)

The following table shows wiring connections to both XMTR and RCVR modules:

Connector	Pin	XMTR Module Signal Description	RCVR Module Signal Description
J1	1	Ground (Input)	Ground (Input)
	2	+Uin Supply (Input, same as Vin))	+Uin Supply (Input)
J2	1	Ground (To Encoder)	Ground (To Drive)
	2	+Ub Supply (To Encoder, same as +Vb)	+Ub Supply (Optional use, same as +Ub)
	3	Channel A+ (From Encoder)	Channel A+ (To Drive)
	4	Channel A- (From Encoder)	Channel A- (To Drive)
	5	Channel B+ (From Encoder)	Channel B+ (To Drive)
	6	Channel B- (From Encoder)	Channel B- (To Drive)
	7	Channel C+/Index+ (From Encoder)	Channel C+/Index+ (To Drive, if used)
	8	Channel C-/Index- (From Encoder)	Channel C-/Index- (To Drive, if used)
	9	Channel D+ (From Encoder, if used)	Channel D+ (To Drive, if used))
	10	Channel D- (From Encoder, if used)	Channel D- (To Drive, if used)
	11	Cable Shield	Cable Shield

Note: In Germany, U is the abbreviation for voltage whereas the USA and others use V
Hence, Uin=Vin (external power input) and Ub=Vb (encoder power input)

IMPORTANT NOTE: Inputs and outputs should be terminated as shown in *Figure 6*.

Unused input pairs to XMTR should be terminated as follows:

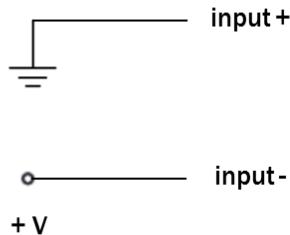

All RCVR outputs should be terminated at far end as follows:

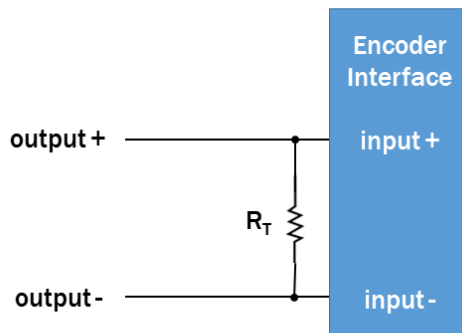

R_T required for cabling >10 meters, optional for shorter distances:

For RS422 outputs, $R_T=120 \Omega$
For HTL/Push-Pull outputs, $R_T=2K \Omega$

Figure 6. How to terminate XMTR inputs or RCVR outputs

4.4. System Start-Up & Performance Check

With all optical and electrical connections made to both XMTR and RCVR modules, the green LED on the front of each module displays status. Figure 7 illustrates the meaning of the status LED for both XMTR and RCVR modules.

The status LEDs do not indicate if encoder signals are active. The system transmits exactly what it sees at the inputs of the XMTR module. Best encoder wiring and cabling practices must be followed to make sure that the encoder signal inputs are clean and properly grounded. Signal integrity should be verified with an oscilloscope.

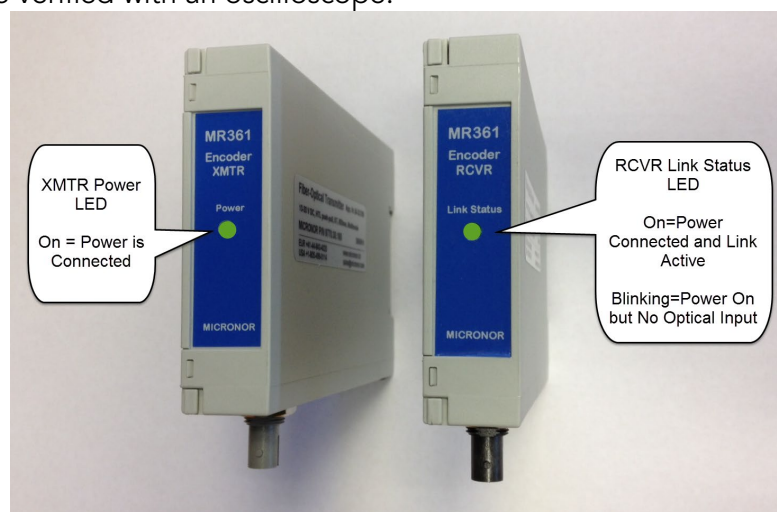

Figure 7. Meaning of Status LED on XMTR and RCVR Modules

5. Troubleshooting

The following are potential issues and recommended solutions when troubleshooting the MR361 Fiber Optic Encoder Link system. For issues not listed, please contact Micronor Sales.

5.1. Potential Issues & Solutions

5.1.1. XMTR Power Green LED not ON when controller powered

- Verify solid electrical connection between wires and screw terminal for both +Uin/+Vin and GND.
- Verify that external power supply is rated correctly for the encoder being used and connected
- Contact Micronor Sales for further assistance.

5.1.2. RCVR Link Status LED not ON when controller powered

- Verify solid electrical connection between wires and screw terminal for both +Uin/+Vin and GND.
- Verify that external power supply is rated correctly for the drive inputs.
- Contact Micronor Sales for further assistance.

5.1.3. RCVR Link Status LED Blinks

- Verify optical link cabling is properly connected and undamaged. A visual fault finder is an inexpensive tool for verifying continuity.
- Measure RCVR end of link with an optical power meter. Should read at least -24 dBm.
- Verify that the entire fiber optic system does not exceed system loss margin specifications. Use either an optical power meter or OTDR to trace the link.
- Clean all fiber optic connector surfaces using appropriate cleaning materials.
- Contact Micronor Sales for further assistance.

5.1.4. RCVR Encoder Outputs not working but both LEDs On

- If accessible, verify outputs of Encoder using oscilloscope
- Verify A/B/C/D inputs to XMTR module using oscilloscope
- Verify A/B/C/D outputs of RCVR module using oscilloscope
- Contact Micronor Sales for further assistance.

5.2. Damaged In Shipment

In the event of a damaged instrument, write or call your nearest MICRONOR office in the USA or Europe. Please retain the shipping container in case reshipment is required for any reason.

If you receive a damaged instrument you should:

- 1) Report the damage to your shipper immediately.
- 2) Inform MICRONOR
- 3) Save all shipping cartons.

Failure to follow this procedure may affect your claim for compensation.

6. Warranty Information

Warranty

MICRONOR warrants this product to be free from defects in material and workmanship for a period of 1 (one) year from date of shipment. During the warranty period we will, at our option, either repair or replace any product that proves to be defective.

To exercise this warranty, write or call your local MICRONOR representative or contact MICRONOR headquarters. You will be given prompt assistance and return instructions. Send the instrument, transportation prepaid, to the indicated service facility. Repairs will be made and the instrument returned transportation prepaid. Repaired products are warranted for the balance of the original warranty period, or at least 90 days.

Limitations of Warranty

This warranty does not apply to defects resulting from unauthorized modification or misuse of any product or part. This warranty also does not apply to Fiber Optic Connector interfaces, fuses, power supplies or AC line cords. This warranty is in lieu of all other warranties, expressed or implied, including any implied warranty of merchantability of fitness for a particular use. MICRONOR shall not be liable for any indirect, special or consequent damages.

Contact Information:

For North and South America:

Micronor Sensors
2085 Sperry Ave, Suite A-1
Ventura, CA 93003
USA

Phone +1-805-389-6600
Email sales@micronor.com
URL www.micronor.com

For Europe, Middle East, Asia, Africa:

Micronor AG
Pumpwerkstrasse 32
CH-8015 Regensdorf
SWITZERLAND

Phone +41-44-843-4020
Fax +41-44-843-4039
Email sales@micronor.ch
URL www.micronor.ch

7. Specifications

Encoder Types/Part Numbers	XMTR Module P/N	RCVR Module P/N
<u>Encoder Type 1</u> +5 VDC Input Power RS422 Differential Line Driver Outputs Up to 4 Channels A+/A-/B+/B-/C+/C-/D+/D-	9770.30.100	9770.30.200
<u>Encoder Type 2</u> +10-30 VDC Input Power RS422 Differential Line Driver Outputs Up to 4 Channels A+/A-/B+/B-/C+/C-/D+/D-	9770.30.140	9770.30.210
<u>Encoder Type 3</u> +10-30 VDC Input Power HTL or Push-Pull Differential Line Driver Outputs Up to 4 Channels A+/A-/B+/B-/C+/C-/D+/D-	9770.30.160	9770.30.220
Optical Specifications	Specification	
Fiber Optic Interface	ST-PC	
Fiber Optic Cabling	OM1, 62.5/125µm Graded Index MMF	
Link Distance	Lesser of 6 dB or 2 km	
Optical Transmitter	850nm LED	
Input Sampling Rate (Per Channel)	2 MHz	
Electrical Specifications	Specification	
Electrical Interface	Phoenix Combicon MC 3.5mm Screw Terminal Plugs One each supplied with each module:	
Module Power (J1) Encoder Connections (J2)	J1: 2C Plug, Phoenix P/N 1840366 J2: 11C Plug, Phoenix P/N 140450	
Power Supply Requirements		
+5V XMTR Module +5V RCVR Module	160 mA + Encoder Power Consumption 160 mA + Line Termination Consumption	
+10-30V XMTR Module +10-30V RCVR Module	110 mA + Encoder Power Consumption 110 mA + Line Termination Consumption	
Encoder Connections		
Quadrature Outputs	Up to 4 channels (A/B/C/D), RS422/TTL, HTL/Push-Pull Differential or Unipolar, Depending on Model	
Encoder Power	These terminals are directly connected to J1 Module Power Input	
Environmental Specifications	Specification	
Temperature Range	-10°C to +65°C (-14°F to +149°F)	
Humidity	0% to 90% RH (non-condensing)	
Ingress Protection	IP40	
Physical Specifications	Specification	
Mounting	35mm DIN Rail	
Housing	18 x 111 x 88 mm (0.70 x 4.37 x 3.47 inches)	
Weight	65 g (2.25 oz)	

Specifications subject to change without notice

8. Theory of Operation

A functional block diagram is shown in *Figure 8*, showing the Encoder, XMTR module, optical link, RCVR module and Remote Motor Drive encoder input connections. The system can accommodate up to 4 channels (A/B/C/D) although most systems use just A/B or A/B/Index for encoder feedback. In addition, 2 encoders can be served by one link if only A/A'/B/B' signals are used.

The Encoder connections to the XMTR module are electrically multiplexed and then transmitted optically over a simplex fiber optic link. The optical input signal to the RCVR is then converted back to the electrical domain and demultiplexed back into same 4-channel encoder signals. The RCVR outputs are then connected to the encoder inputs of the Motor Drive (or similar motion control system interface).

The end-to-end conversion and optical transmission process is completely transparent to the Remote Motor Drive. The MR361 system simply extends the reach of the Encoder using fiber optic transmission techniques.

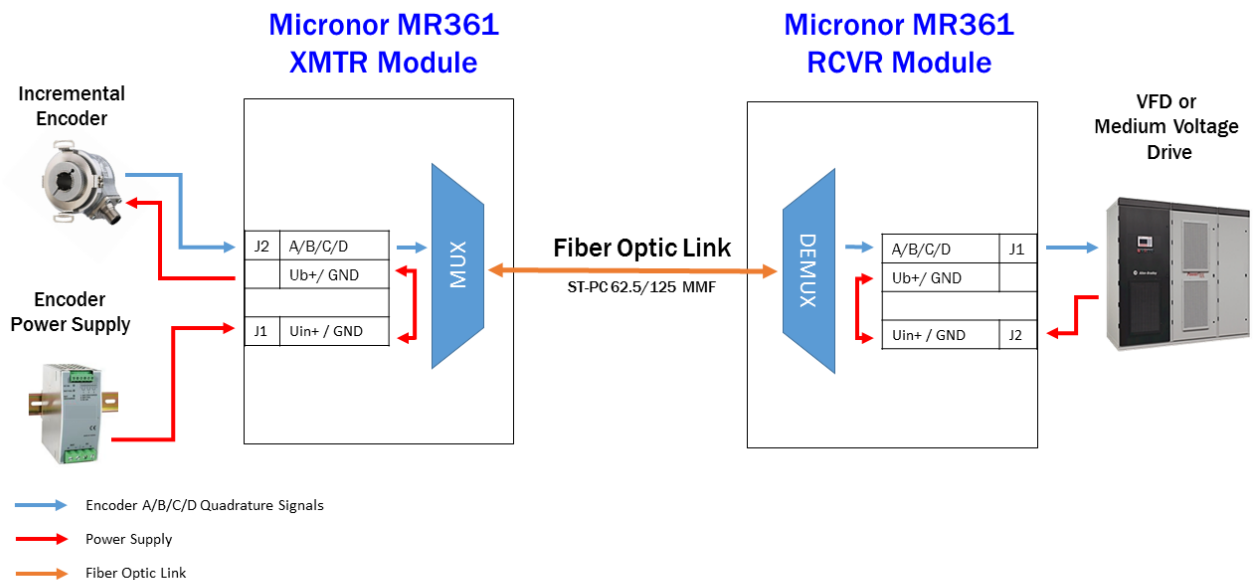

Figure 8. Theory of Operation of MR361 Fiber Optic Encoder Link System

9. Applications

9.1. Using unused XMTR inputs for signaling inputs.

Traditional encoders have only A/B or A/B/Index outputs. That leaves 1 (D) or 2 (C & D) unused input channels that could be used for routing additional signaling inputs as shown in the example of Figure 9 .

How to use an unused XMTR input for signaling:

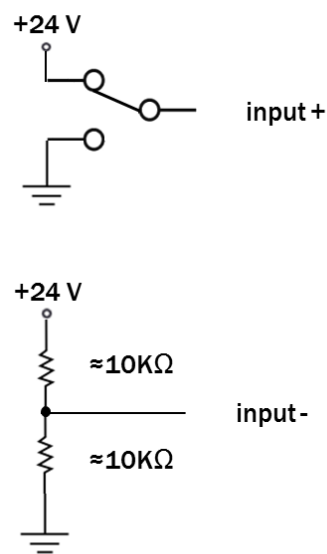
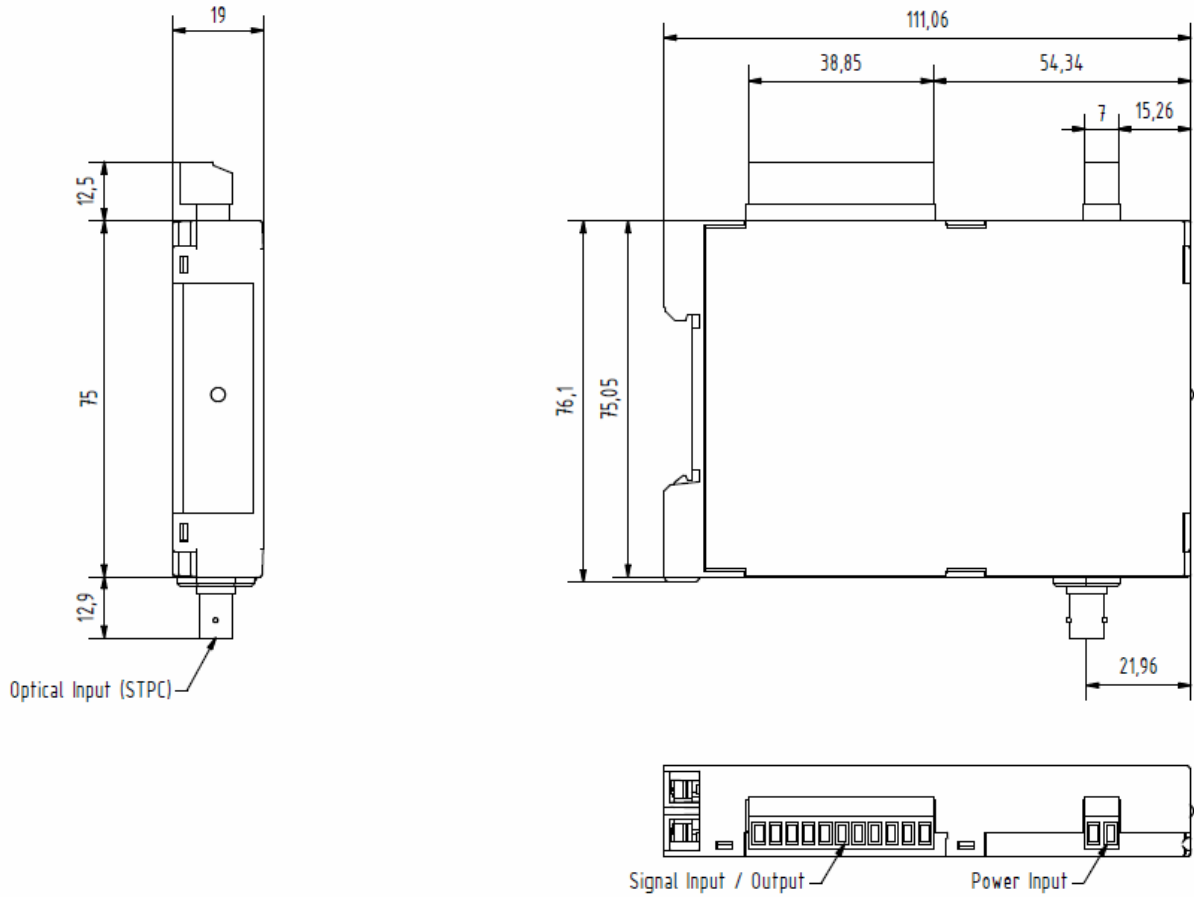

Figure 9. How to use unused XMTR inputs for signaling inputs

10. Mechanical Reference Drawing

The XMTR and RCVR modules are the same size and dimensions.



Dimensions in mm