

R11XF107

SIZE 11 BRUSHLESS RESOLVER WITH SHAFT

MICRONOR
automation components

Products

R11XF107 is a Size 11, Control Transmitter-type Brushless Resolver. It is a single speed resolver, optimized for 2500 Hz excitation, TR=0.5 and ± 7 arcmin (0.12°) accuracy.



Diagram

Lead Color	Function
Red/White	Rotor 1
Black/White	Rotor 2
Red	Stator 1
Yellow	Stator 2
Black	Stator 3
Blue	Stator 4

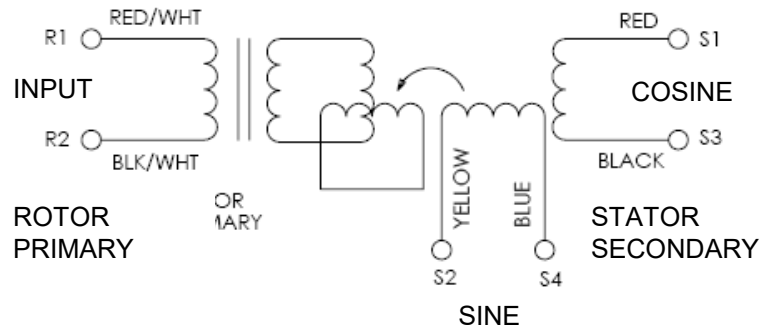

Specifications

Specifications Subject To Change Without Notice

Parameters measured at 25 °C

Speed	1
Excitation Frequency	2500 Hz $\pm 5\%$
Transformation Ratio (TR)	0.50 $\pm 5\%$
Input Voltage and Frequency	7.0 V, 2500 Hz
Input Current	18 mA max.
Input Power	90 mW max.
Output Voltage	3.5 V
Impedances (Ohms)	
ZRO	175 + j170
ZRS	108 + j121
ZSO	165 + j182
ZSS	100 + j128
Phase Shift (Degree Leading)	+6°
DC Rotor Resistance (Ohms)	16 Ω
DC Stator Resistance (Ohms)	40 Ω
Total Null Voltage (mV)	15
Accuracy Max Error (at 25°C)	± 7 arcmin (0.12°)
Shaft Loading (Max.)	2 lbs. radial / 1 lbs. axial
Starting Torque	0.08 oz-in
Moment of Inertia	0.51×10^{-4} oz-in-sec ²
Operating Temperature	-40°C to +125°C

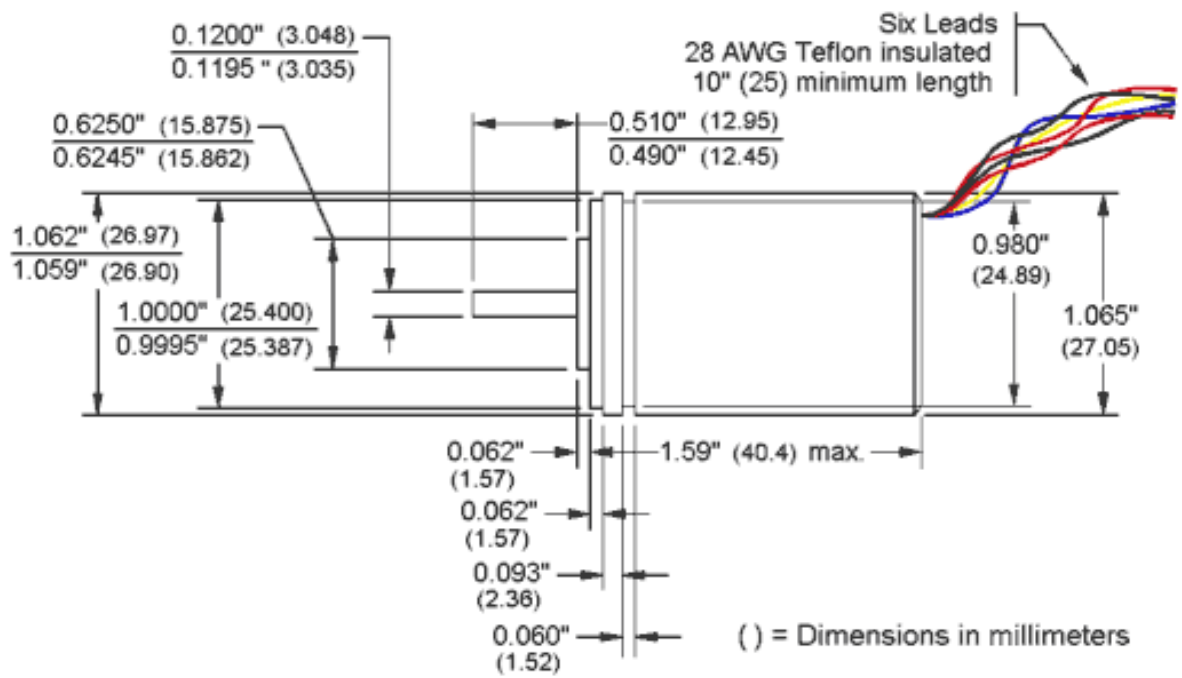

Part Number To Order:

R11XF107

Related Items:

- R11BHW50FF533 replaces Micron 73-206-879 / Clifton 11-BHW-50F/F533
- R11WF103 replaces Micron 73-202-730 / Harowe 11BRW-300-F95A
- R11XJ107 replaces Micron 73-206-879 / Harowe 11BRCX-300-J95C

For additional technical information, contact Micronor and request:

- MICRON Replacement Position Transducers Data Sheet

MICRONOR INC.

900 Calle Plano, Suite K
Camarillo, CA 93012
USA
T +1-805-389-6600
F +1-805-389-6605
sales@micronor.com
www.micronor.com

MICRONOR AG

Pumpwerkstrasse 32
CH-8105 Regensdorf
Switzerland
T +41-44-843-4020
F +41-44-843-4039
sales@micronor.ch
www.micronor.com